

LINE	GRADE	SCOPE	QTY	DESCRIPTION	LENGTH	MARK	REMARK
	-		144	ANCHOR_RODS		ADV1	NO PAINT
	F1554-GR.36		144	ROD3/4"	2'-0 1/2"	ADV1	

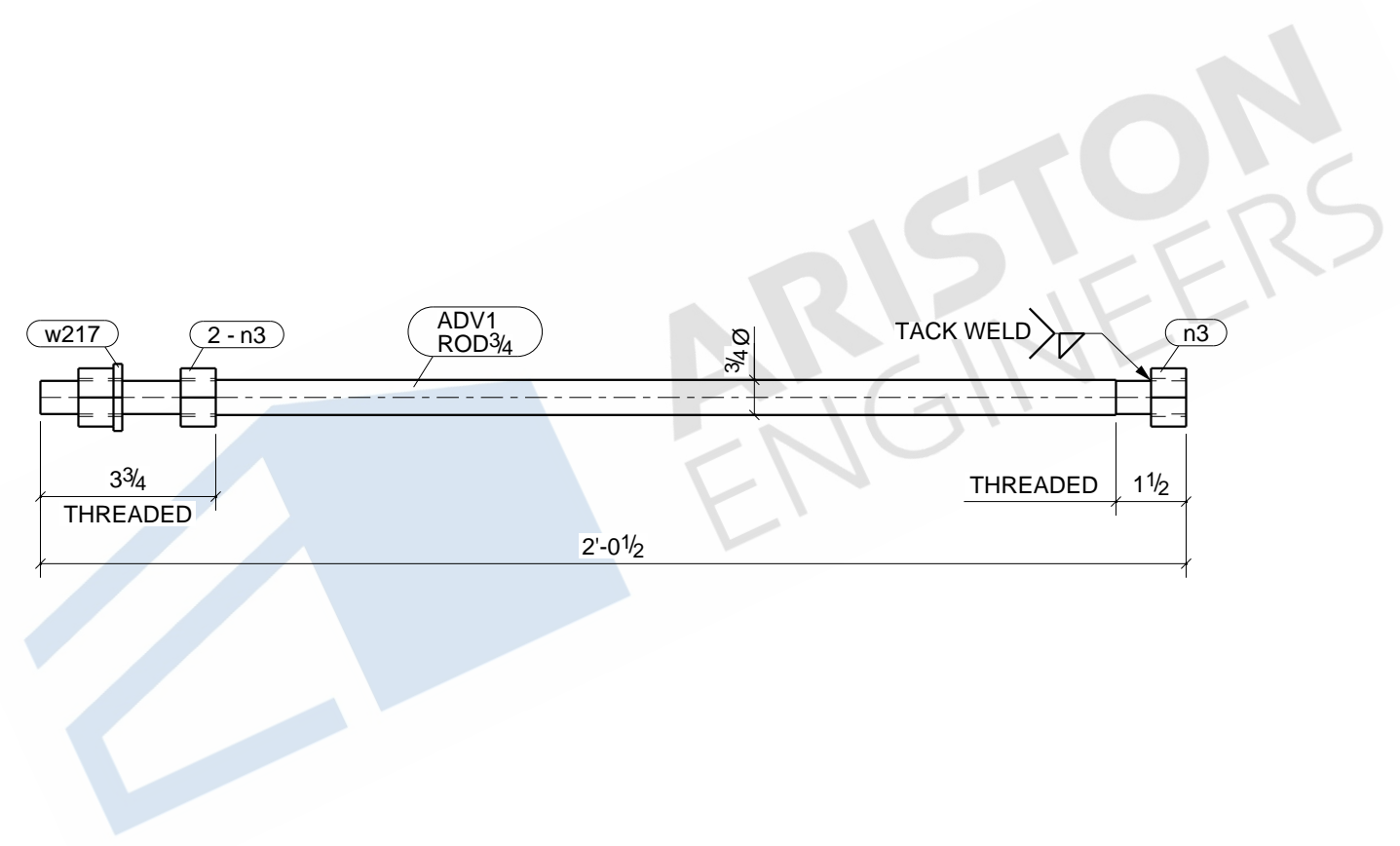
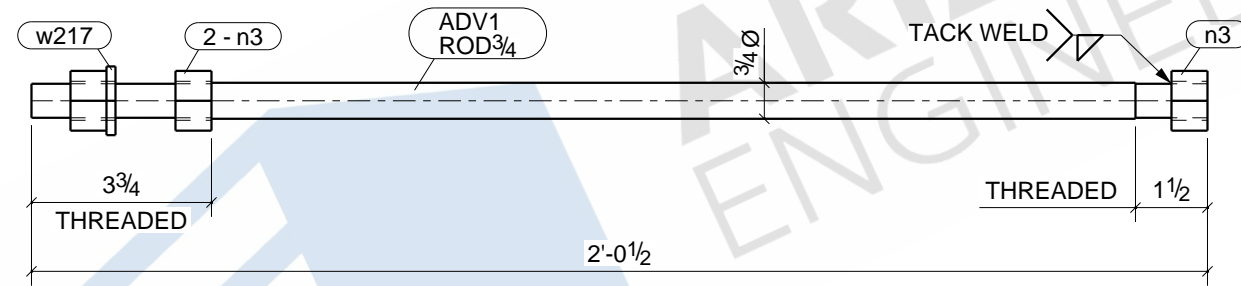

Tekla structures

144 - ANCHOR_RODS - ADV1

BOLT : 3/4" A325N UNO		MATERIAL	
HOLES : 13/16" UNO		W SHAPES = A992 TUBES = A500 (46 KSI) SHOP PREP PER SPECS	
WELD : E-70XX		FINISH : NO PAINT	
REVISIONS		ITEM	ADV1 - ANCHOR_ROD
NO	DESCRIPTION	DATE	JDA MADISON SELF STORAGE
		ARCH	
		CONTR	
DWN : ASM	DATE:	CHK'D: NSP	DATE:
JOB#		DWG NO.	ADV1

LINE	GRADE	SCOPE	QTY	DESCRIPTION	LENGTH	MARK	REMARK
	-		73	BEARING PLATES		S-BP201	NO PAINT
	A36		73	PL3/8"X4"	0'-6"	S-BP201	
	A108		146	STUD_3/4-DIA	0'-4"		

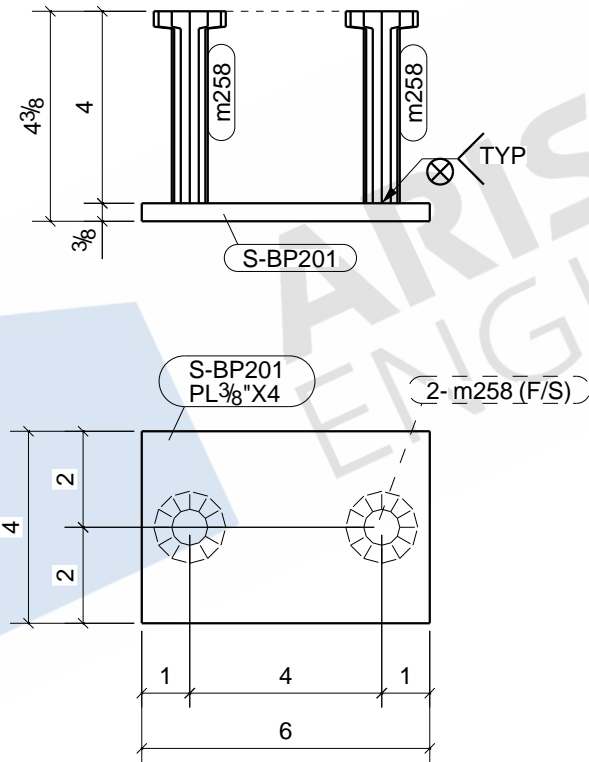

73 - BEARING PLATES - S-BP201

BOLT : 3/4" A325N UNO		MATERIAL	
HOLES : 13/16" UNO		W SHAPES = A992 TUBES = A500 (46 KSI) SHOP PREP PER SPECS	
WELD : E-70XX		FINISH : NO PAINT	
REVISIONS		ITEM	S-BP201 - ANGLE
NO	DESCRIPTION	DATE	JDA MADISON SELF STORAGE
		ARCH	
		CONTR	
DWN : ASM		DATE:	CHK'D: NSP
JOB#			DATE:
		DWG NO.	S-BP201

LINE	GRADE	SCOPE	QTY	DESCRIPTION	LENGTH	MARK	REMARK
	-		1	BEAM		1B1	NO PAINT
	A992		1	W12X14	7'-0"	1B1	
	-		6	1"Ø A490N BOLT	0'-2 1/4"		FIELD BOLT

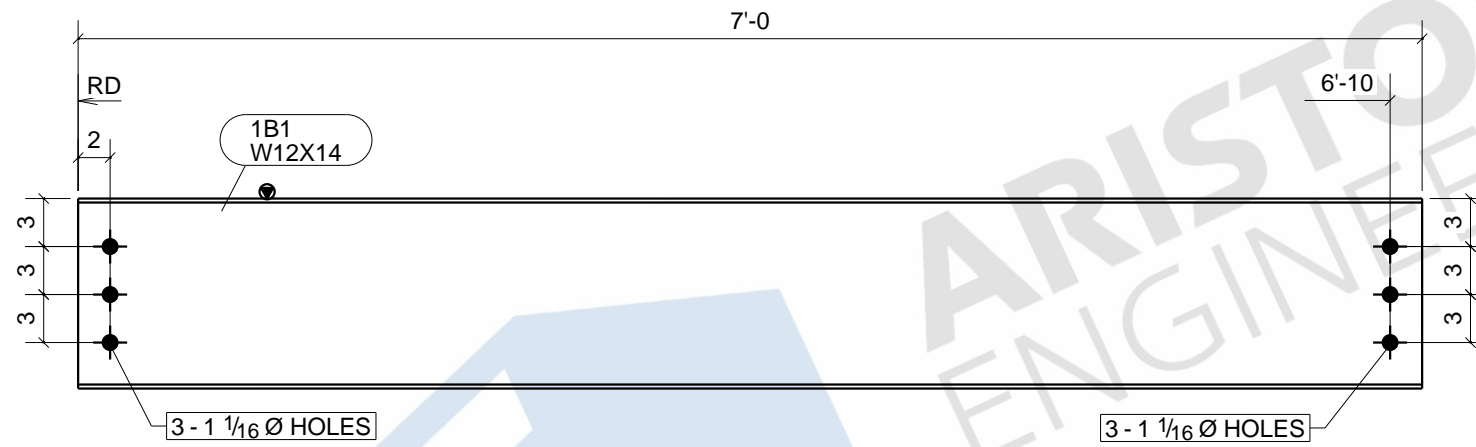

ONE - BEAM - 1B1

BOLT : 3/4" A325N UNO		MATERIAL	
HOLES : 13/16" UNO		W SHAPES = A992 TUBES = A500 (46 KSI) SHOP PREP PER SPECS	
WELD : E-70XX		FINISH : NO PAINT	
REVISIONS		ITEM	1B1 - BEAM
NO	DESCRIPTION	DATE	JDA MADISON SELF STORAGE
		ARCH	
		CONTR	
DWN : ASM	DATE:	CHK'D: NSP	DATE:
JOB#		DWG NO.	1B1

LINE	GRADE	SCOPE	QTY	DESCRIPTION	LENGTH	MARK	REMARK
-	-	-	1	BEAM		1B2	NO PAINT
A992	-	-	1	W12X14	9'-5"	1B2	
-	-	-	6	1"Ø A490N BOLT	0'-2 1/4"		FIELD BOLT

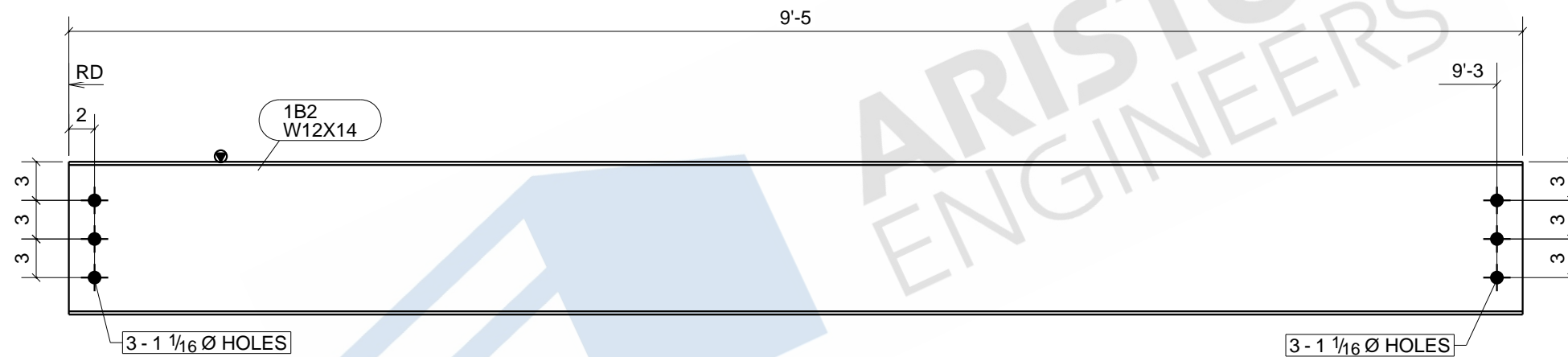

ARISTON ENGINEERS

ONE - BEAM - 1B2

BOLT : 3/4" A325N UNO		MATERIAL	
HOLES : 13/16" UNO		W SHAPES = A992 TUBES = A500 (46 KSI) SHOP PREP PER SPECS	
WELD : E-70XX		FINISH : NO PAINT	
REVISIONS		ITEM	1B2 - BEAM
NO	DESCRIPTION	DATE	JDA MADISON SELF STORAGE
		ARCH	
		CONTR	
DWN : ASM	DATE:	CHK'D: MVK	DATE:
JOB#		DWG NO.	1B2

LINE	GRADE	SCOPE	QTY	DESCRIPTION	LENGTH	MARK	REMARK
-	-	-	11	BEAMS		1B3	NO PAINT
A992			11	W8X10	9'-5"	1B3	
-			44	3/4"Ø A325N BOLT	0'-1 3/4"		FIELD BOLT

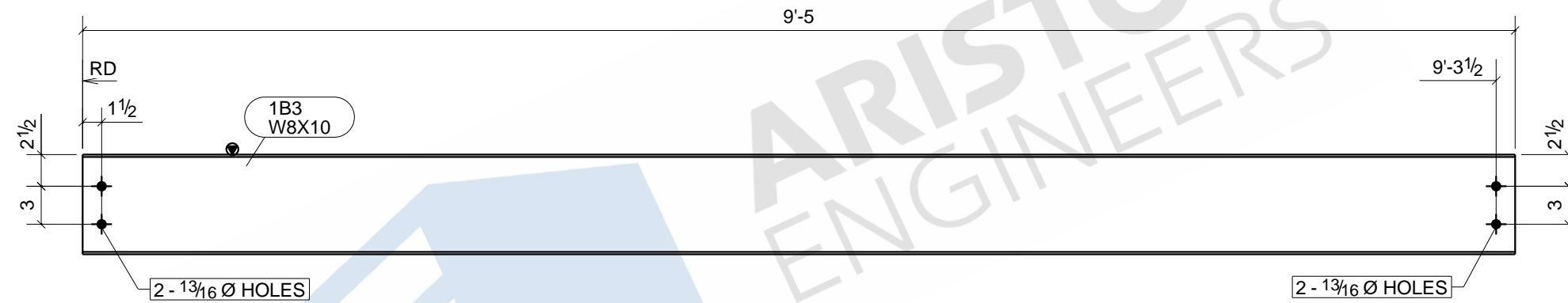

ARISTON
ENGINEERS

11 - BEAMS - 1B3

BOLT : 3/4" A325N UNO		MATERIAL	
HOLES : 13/16" UNO		W SHAPES = A992 TUBES = A500 (46 KSI) SHOP PREP PER SPECS	
WELD : E-70XX		FINISH : NO PAINT	
REVISIONS		ITEM	1B3 - BEAM
NO	DESCRIPTION	DATE	JDA MADISON SELF STORAGE
		ARCH	
		CONTR	
DWN : ASM		DATE:	CHK'D: NSP
JOB#			DATE:
		DWG NO.	1B3

Tekla structures

LINE	GRADE	SCOPE	QTY	DESCRIPTION	LENGTH	MARK	REMARK
-	-	-	1	BEAM		1B4	NO PAINT
A992			1	W8X10	4'-3 3/4"	1B4	
A36			2	L6X4X3/8	0'-6"	a40	
A36			1	PL1/4"X11 5/16"	4'-3 3/4"	bpl13	
-			2	1/2"Ø WEDGE_ANC BOLT	0'-4 1/2"		FIELD BOLT
-			2	3/4"Ø A325N BOLT	0'-1 3/4"		FIELD BOLT

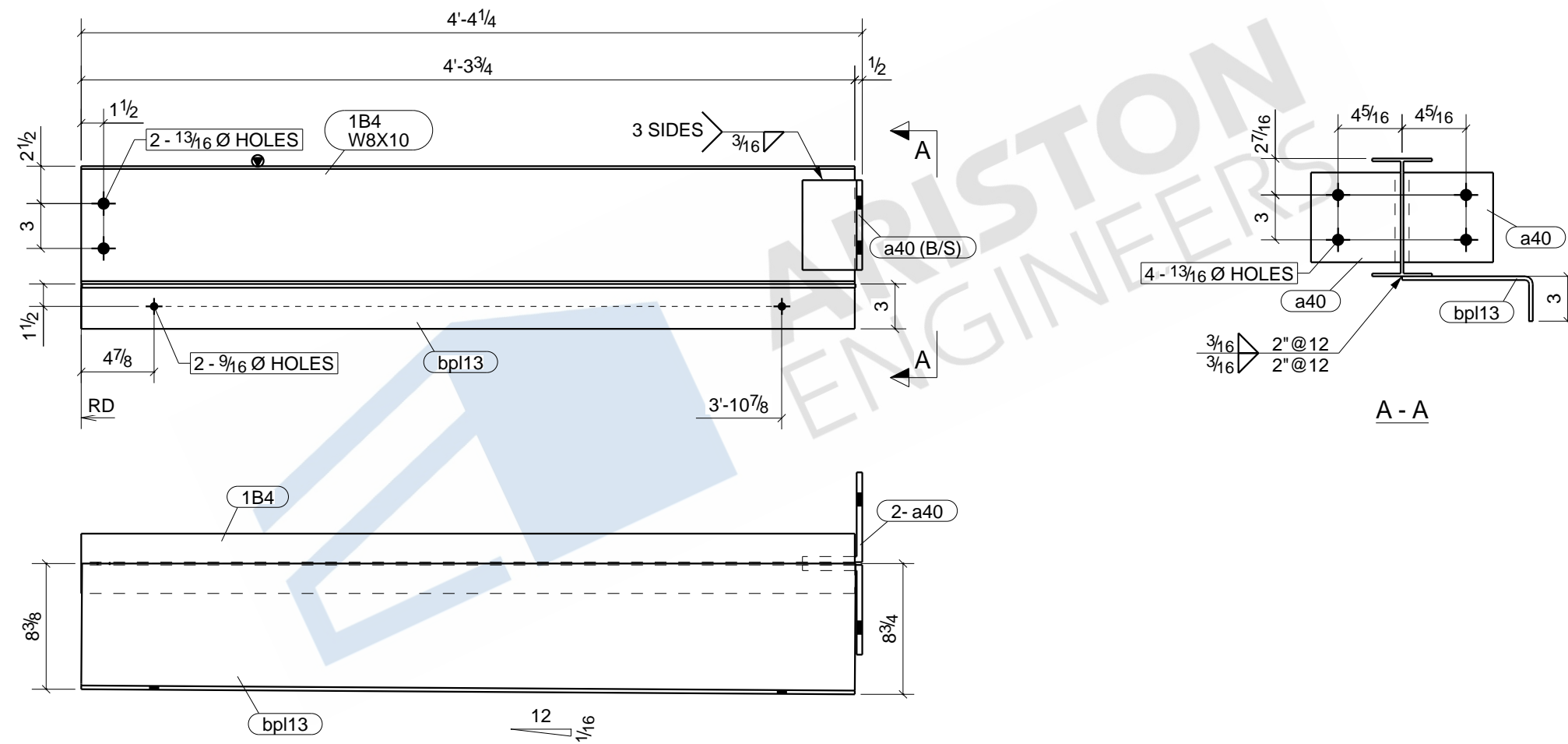

ONE - BEAM - 1B4

BOLT : 3/4" A325N UNO		MATERIAL	
HOLES : 13/16" UNO		W SHAPES = A992	
WELD : E-70XX		TUBES = A500 (46 KSI)	
FINISH : NO PAINT		SHOP PREP PER SPECS	
REVISIONS		ITEM	1B4 - BEAM
NO	DESCRIPTION	DATE	JDA MADISON SELF STORAGE
		ARCH	
		CONTR	
DWN : ASM	DATE:	CHK'D: NSP	DATE:
JOB#		DWG NO.	1B4

LINE	GRADE	SCOPE	QTY	DESCRIPTION	LENGTH	MARK	REMARK
-	-	-	2	BEAMS		1B5	NO PAINT
A992	-	-	2	W12X14	8'-11"	1B5	
-	-	-	12	1"Ø A490N BOLT	0'-2 1/4"		FIELD BOLT

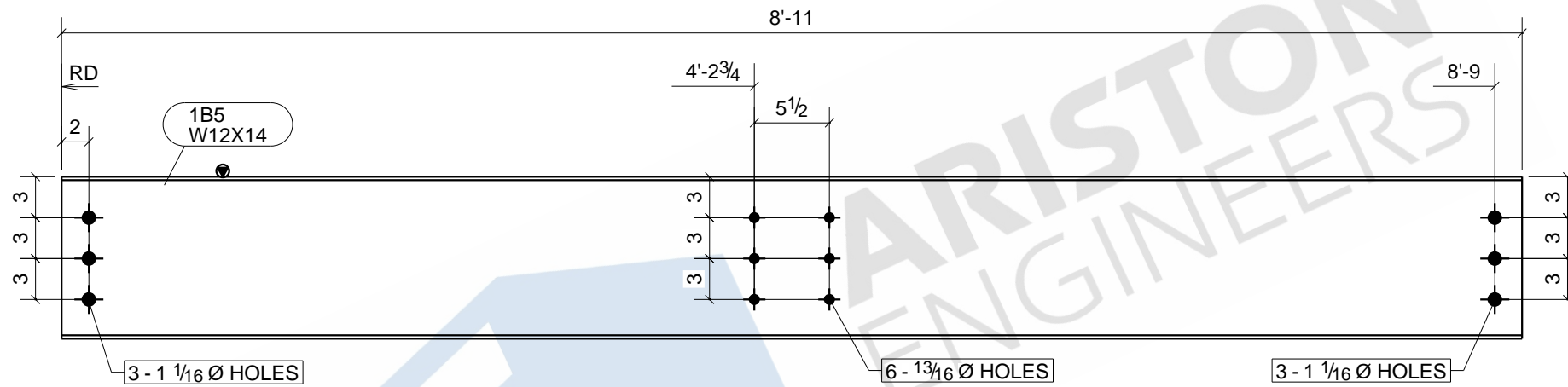

2 - BEAMS - 1B5

BOLT : 3/4" A325N UNO		MATERIAL	
HOLES : 13/16" UNO		W SHAPES = A992	
WELD : E-70XX		TUBES = A500 (46 KSI)	
FINISH : NO PAINT		SHOP PREP PER SPECS	
REVISIONS		ITEM	1B5 - BEAM
NO	DESCRIPTION	DATE	JDA MADISON SELF STORAGE
		ARCH	
		CONTR	
DWN : ASM	DATE:	CHK'D: NSP	DATE:
JOB#		DWG NO.	1B5

LINE	GRADE	SCOPE	QTY	DESCRIPTION	LENGTH	MARK	REMARK
-			1	BEARING_PLATE		1BP1	NO PAINT
A36			1	PL1"X7 1/2"	1'-0"	1BP1	
A108			2	STUD_3/4-DIA	0'-5"	m44	
A36			2	ROD3/4"	0'-2"	r1	

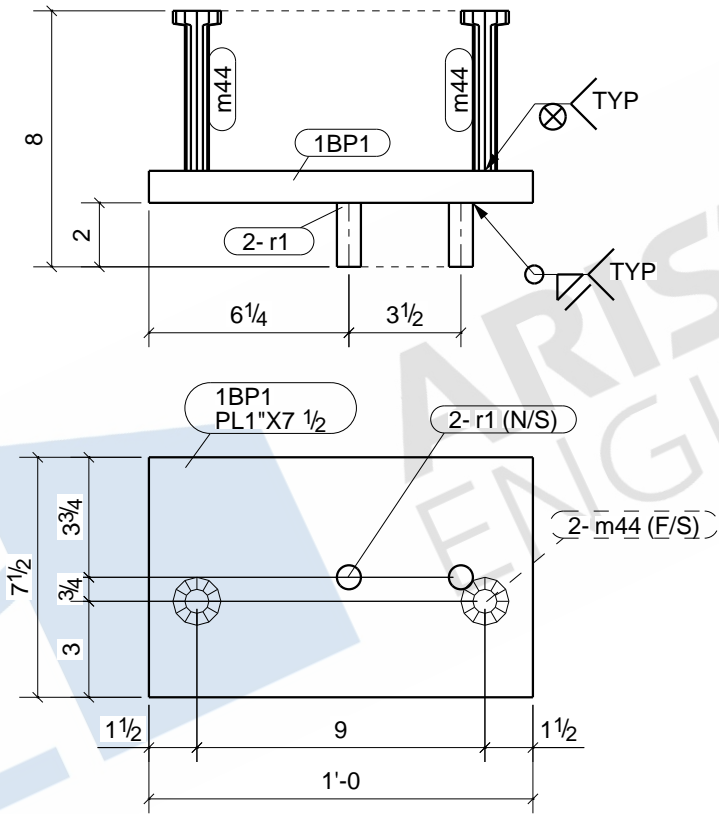

ONE - BEARING_PLATE - 1BP1

BOLT : 3/4" A325N UNO		MATERIAL	
HOLES : 13/16" UNO		W SHAPES = A992 TUBES = A500 (46 KSI) SHOP PREP PER SPECS	
WELD : E-70XX		FINISH : NO PAINT	
REVISIONS		ITEM	1BP1 - BEARING_PLATE
NO	DESCRIPTION	DATE	JDA MADISON SELF STORAGE
		ARCH	
		CONTR	
DWN : ASM	DATE:	CHK'D: NSP	DATE:
JOB#		DWG NO.	1BP1

LINE	GRADE	SCOPE	QTY	DESCRIPTION	LENGTH	MARK	REMARK
-	-	-	3	BEARING_PLATES		1BP2	NO PAINT
A36			3	PL1/2"X7 1/2"	0'-8"	1BP2	
A108			6	STUD_3/4-DIA	0'-5"	m44	
A36			6	ROD3/4"	0'-2"	r1	

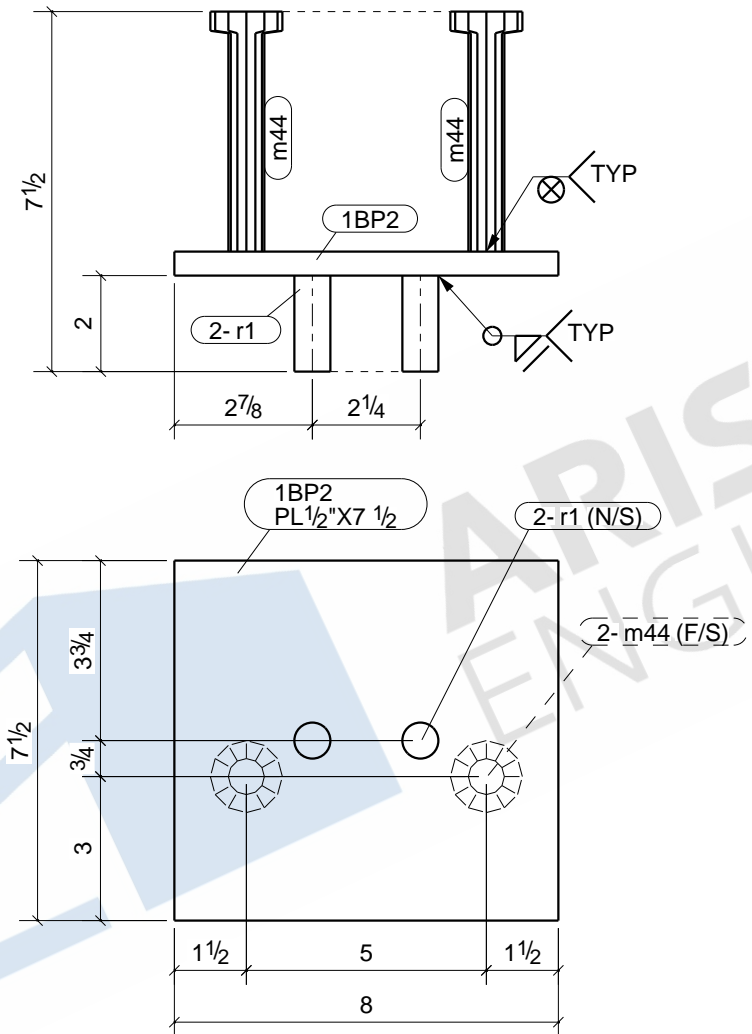

3 - BEARING_PLATES - 1BP2

BOLT : 3/4" A325N UNO		MATERIAL	
HOLES : 13/16" UNO		W SHAPES = A992 TUBES = A500 (46 KSI) SHOP PREP PER SPECS	
WELD : E-70XX		FINISH : NO PAINT	
REVISIONS		ITEM	1BP2 - BEARING_PLATE
NO	DESCRIPTION	DATE	JDA MADISON SELF STORAGE
		ARCH	
		CONTR	
DWN : ASM	DATE:	CHK'D: NSP	DATE:
JOB#		DWG NO.	1BP2

LINE	GRADE	SCOPE	QTY	DESCRIPTION	LENGTH	MARK	REMARK
	-		1	BENT_PLATE		2BPL1	GALVANIZED
	A36		1	PL3/8"X13 3/8"	5'-1"	2BPL1	

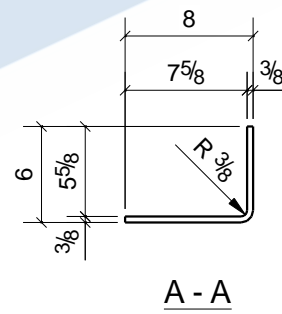
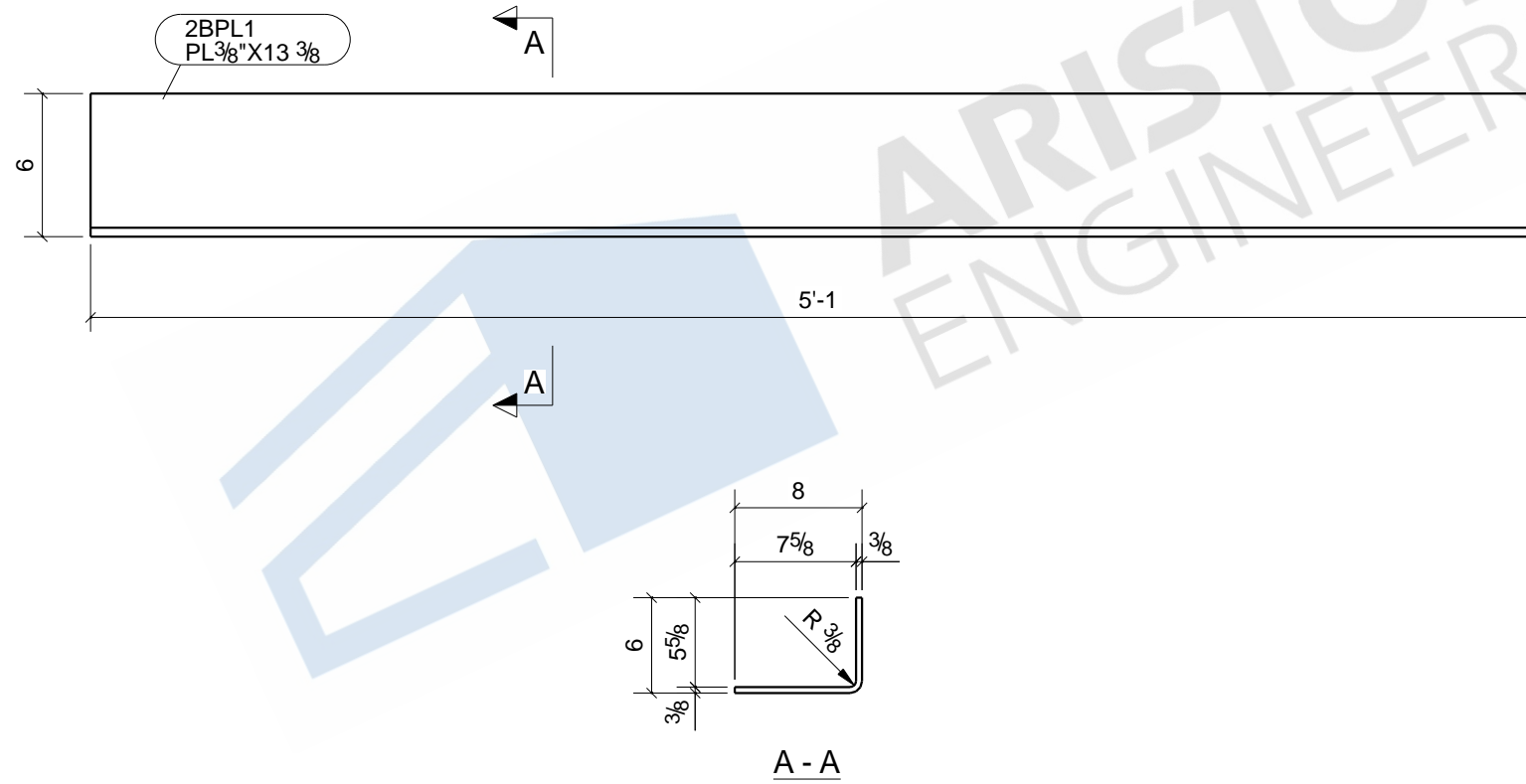

ONE - BENT_PLATE - 2BPL1

BOLT : 3/4" A325N UNO		MATERIAL	
HOLES : 13/16" UNO		W SHAPES = A992 TUBES = A500 (46 KSI) SHOP PREP PER SPECS	
WELD : E-70XX		FINISH : GALVANIZED	
REVISIONS		ITEM	2BPL1 - BENT_PLATE
NO	DESCRIPTION	DATE	JDA MADISON SELF STORAGE
		ARCH	
		CONTR	
DWN : ASM		DATE:	CHK'D: NSP
JOB#			DATE:
		DWG NO.	2BPL1

LINE	GRADE	SCOPE	QTY	DESCRIPTION	LENGTH	MARK	REMARK
	-		2	BENT_PLATES		2BPL2	GALVANIZED
	A36		2	PL3/8"X13 3/8"	10'-0"	2BPL2	

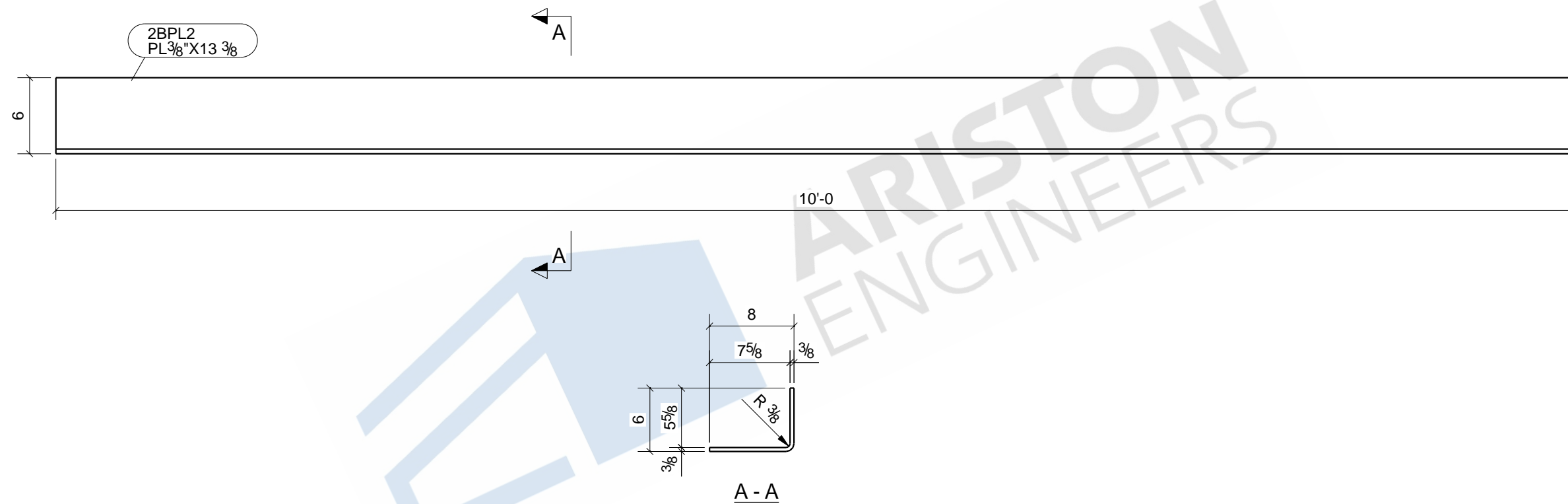

ARISTON ENGINEERS

2 - BENT_PLATES - 2BPL2

BOLT : 3/4" A325N UNO		MATERIAL	
HOLES : 13/16" UNO		W SHAPES = A992 TUBES = A500 (46 KSI) SHOP PREP PER SPECS	
WELD : E-70XX		FINISH : GALVANIZED	
REVISIONS		ITEM	2BPL2 - BENT_PLATE
NO	DESCRIPTION	DATE	JDA MADISON SELF STORAGE
		ARCH	
		CONTR	
		DWN : ASM	DATE:
		CHK'D: NSP	DATE:
		JOB#	DWG NO. 2BPL2

LINE	GRADE	SCOPE	QTY	DESCRIPTION	LENGTH	MARK	REMARK
	-		23	BOLLARDS		BL1	SHOP PRIME
	A53		23	PIPE6SCH40	7'-0"	BL1	

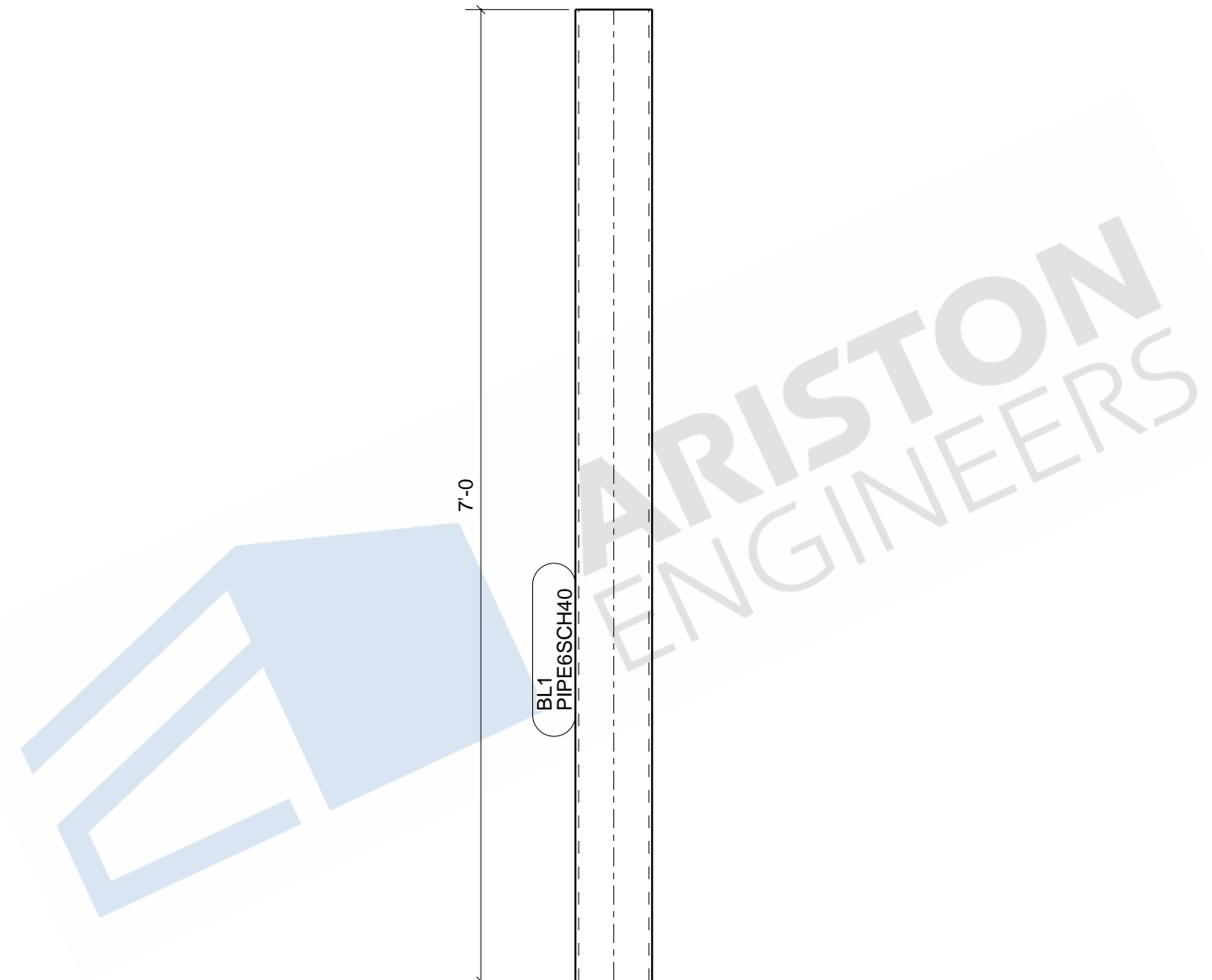

23 - BOLLARDS - BL1

BOLT : 3/4" A325N UNO		MATERIAL	
HOLES : 13/16" UNO		W SHAPES = A992 TUBES = A500 (46 KSI) SHOP PREP PER SPECS	
WELD : E-70XX		FINISH : SHOP PRIME	
REVISIONS		ITEM	BL1 - BOLLARD
NO	DESCRIPTION	DATE	JDA MADISON SELF STORAGE
		ARCH	
		CONTR	
		DWN : ASM	DATE:
		CHK'D: NSP	DATE:
		JOB#	DWG NO. BL1

LINE	GRADE	SCOPE	QTY	DESCRIPTION	LENGTH	MARK	REMARK
	-		1	COLUMN		1C1	NO PAINT
	A500-GR.C		1	HSS6X6X3/8	15'-1 5/8"	1C1	
	A36		1	PL1"X12"	1'-0"	bp8	
	A500-GR.C		1	HSS6X6X3/8	1'-0"	m67	
	A36		2	PL3/8"X3 1/2"	0'-6"	p23	
	A36		1	PL1/2"X8"	0'-10"	p104	

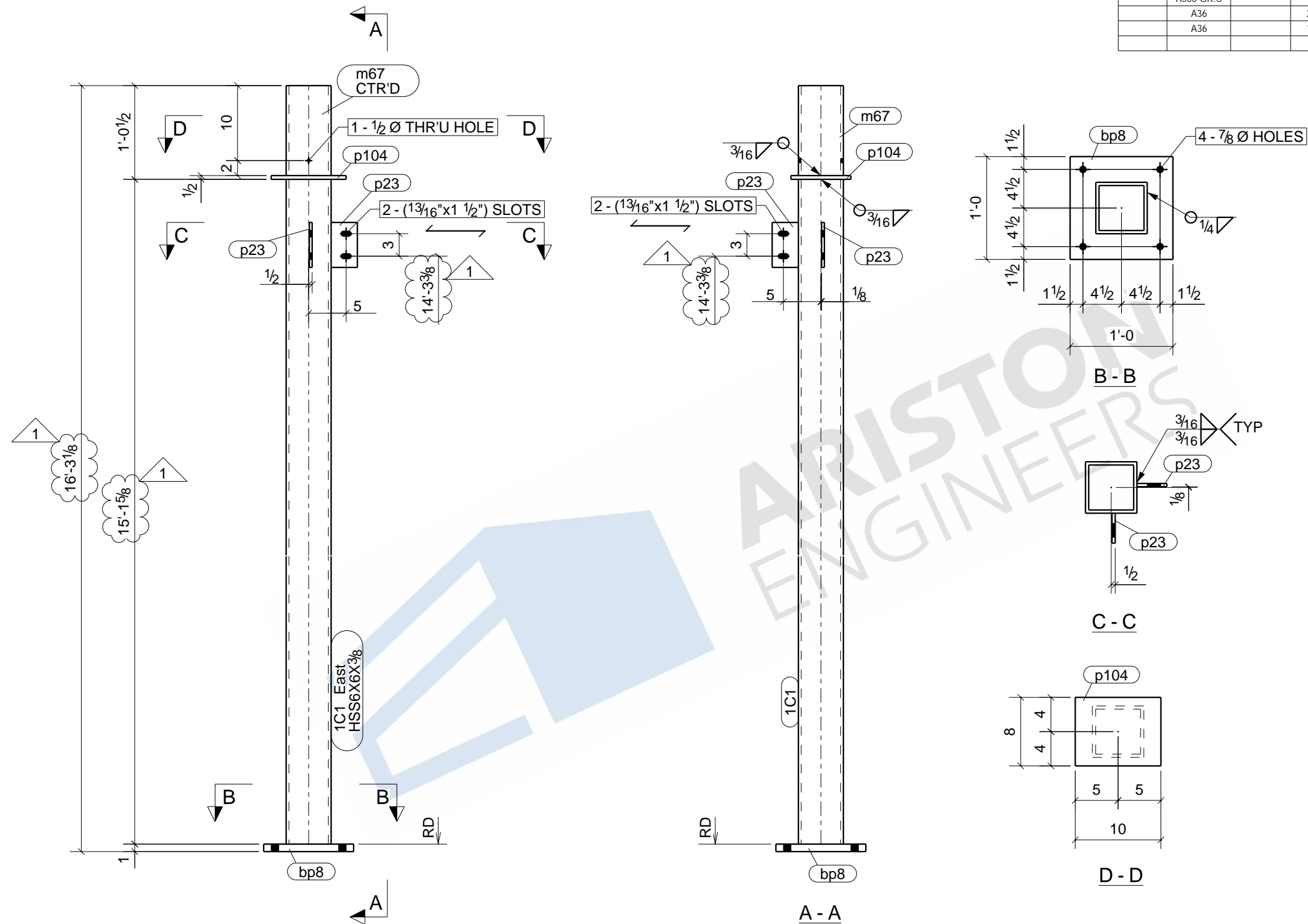

ONE - COLUMN - 1C1

BOLT : 3/4" A325N UNO		MATERIAL	
HOLES : 13/16" UNO		W SHAPES = A992	
WELD : E-70XX		TUBES = A500 (46 KSI)	
FINISH : NO PAINT		SHOP PREP PER SPECS	
REVISIONS		ITEM	1C1 - COLUMN
NO	DESCRIPTION	DATE	JDA MADISON SELF STORAGE
		ARCH	
		CONTR	
DWN : ASM		DATE:	CHK'D: MVK
JOB#		DWG NO.	1C1

LINE	GRADE	SCOPE	QTY	DESCRIPTION	LENGTH	MARK	REMARK
	-		1	COLUMN		1C2	NO PAINT
	A500-GR.C		1	HSS6X6X3/8	1'-9 1/4"	1C2	
	A500-GR.C		1	HSS7X7X3/8	1'-0"	m62	
	A36		1	PL1"x12"	1'-0"	p19	
	A36		1	PL1/2"x8"	0'-10"	p104	
	A36		2	PL3/8"x4 1/2"	0'-9 1/2"	p143	
	-		4	1"Ø SIMPSON BOLT	0'-8"		FIELD BOLT

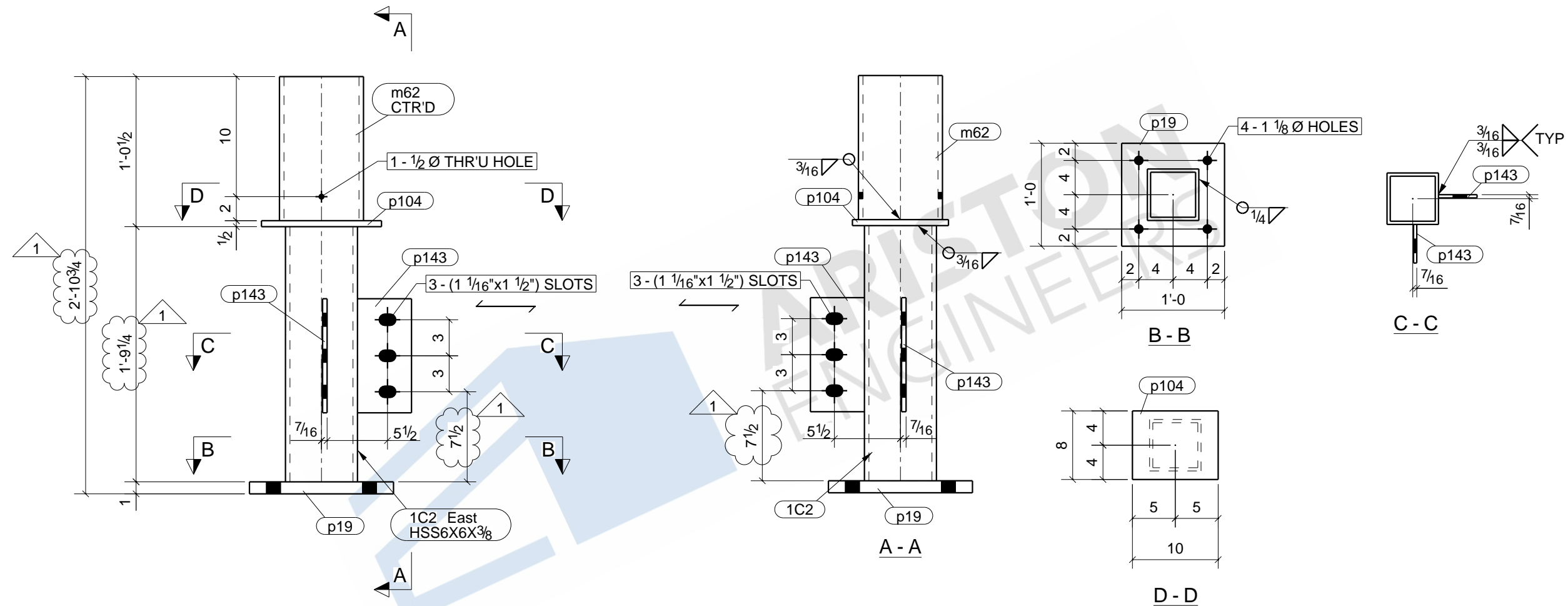

ONE - COLUMN - 1C2

BOLT : 3/4" A325N UNO		MATERIAL	
HOLES : 13/16" UNO		W SHAPES = A992	
WELD : E-70XX		TUBES = A500 (46 KSI)	
FINISH : NO PAINT		SHOP PREP PER SPECS	
REVISIONS		ITEM	1C2 - COLUMN
NO	DESCRIPTION	DATE	JDA MADISON SELF STORAGE
		ARCH	
		CONTR	
DWN : ASM		DATE:	CHK'D: ARP
JOB#			DATE:
		DWG NO.	1C2

LINE	GRADE	SCOPE	QTY	DESCRIPTION	LENGTH	MARK	REMARK
	-		8	COLUMNS		1C3	NO PAINT
	A500-GR.C		8	HSS6X6X3/8	14'-11 1/4"	1C3	
	A500-GR.C		8	HSS6X6X3/8	1'-0"	m67	
	A36		24	PL3/8"x3 1/2"	0'-6"	p23	
	A36		8	PL1/2"x8"	0'-10"	p104	

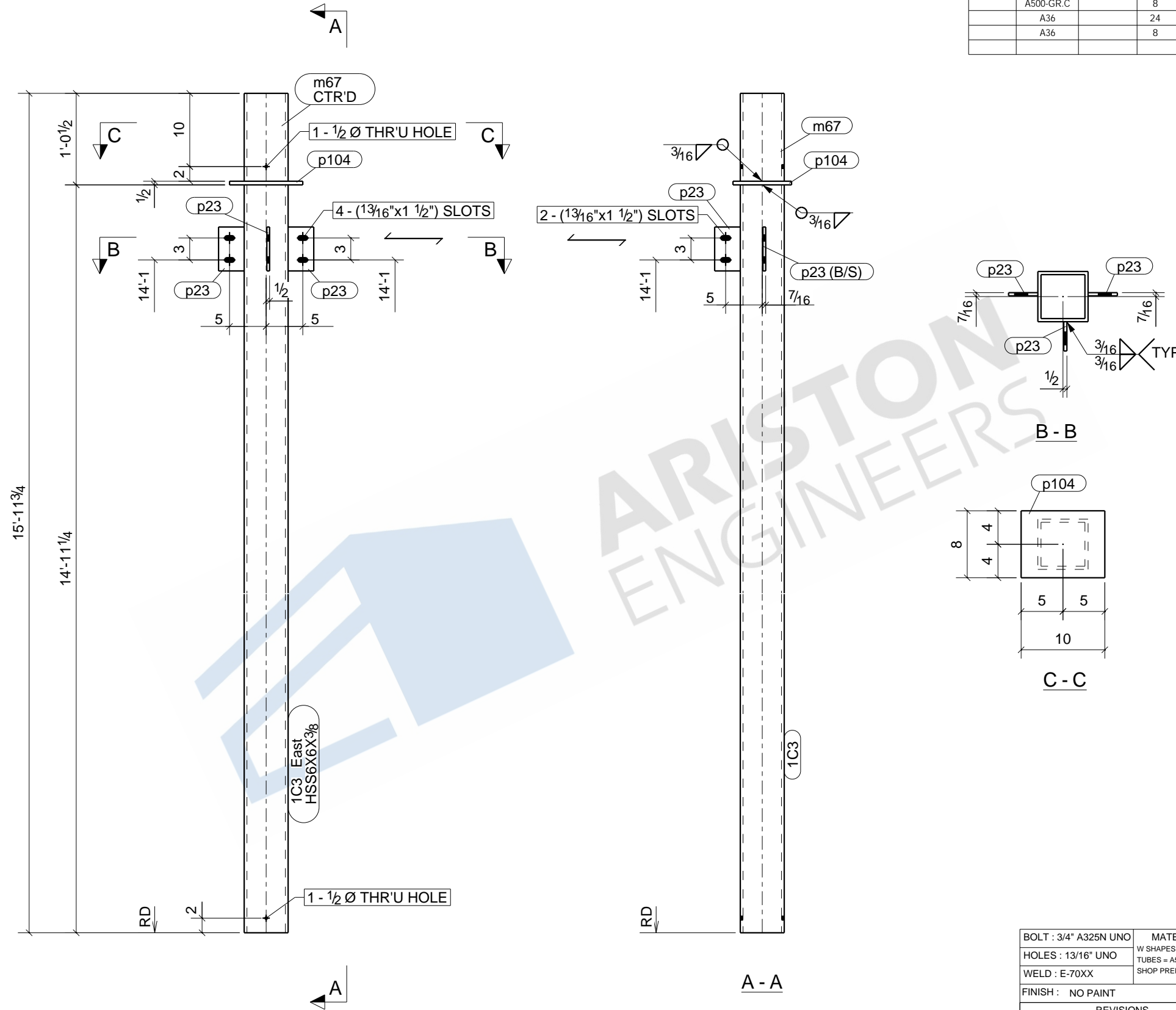

8 - COLUMNS - 1C3

BOLT : 3/4" A325N UNO		MATERIAL	
HOLES : 13/16" UNO		W SHAPES = A992	
WELD : E-70XX		TUBES = A500 (46 KSI)	
FINISH : NO PAINT		SHOP PREP PER SPECS	
REVISIONS		ITEM	1C3 - COLUMN
NO	DESCRIPTION	DATE	JDA MADISON SELF STORAGE
		ARCH	
		CONTR	
DWN : ASM		DATE:	CHK'D: NSP
JOB#		DWG NO.	1C3

LINE	GRADE	SCOPE	QTY	DESCRIPTION	LENGTH	MARK	REMARK
	-		1	COLUMN		1C4	NO PAINT
	A500-GR.C		1	HSS6X6X3/8	1'-9 1/4"	1C4	
	A500-GR.C		1	HSS7X7X3/8	1'-0"	m62	
	A36		1	PL1"x12"	1'-0"	p19	
	A36		1	PL1/2"x8"	0'-10"	p104	
	A36		3	PL3/8"x4 1/2"	0'-9 1/2"	p143	
	-		4	1"Ø SIMPSON BOLT	0'-8"		FIELD BOLT

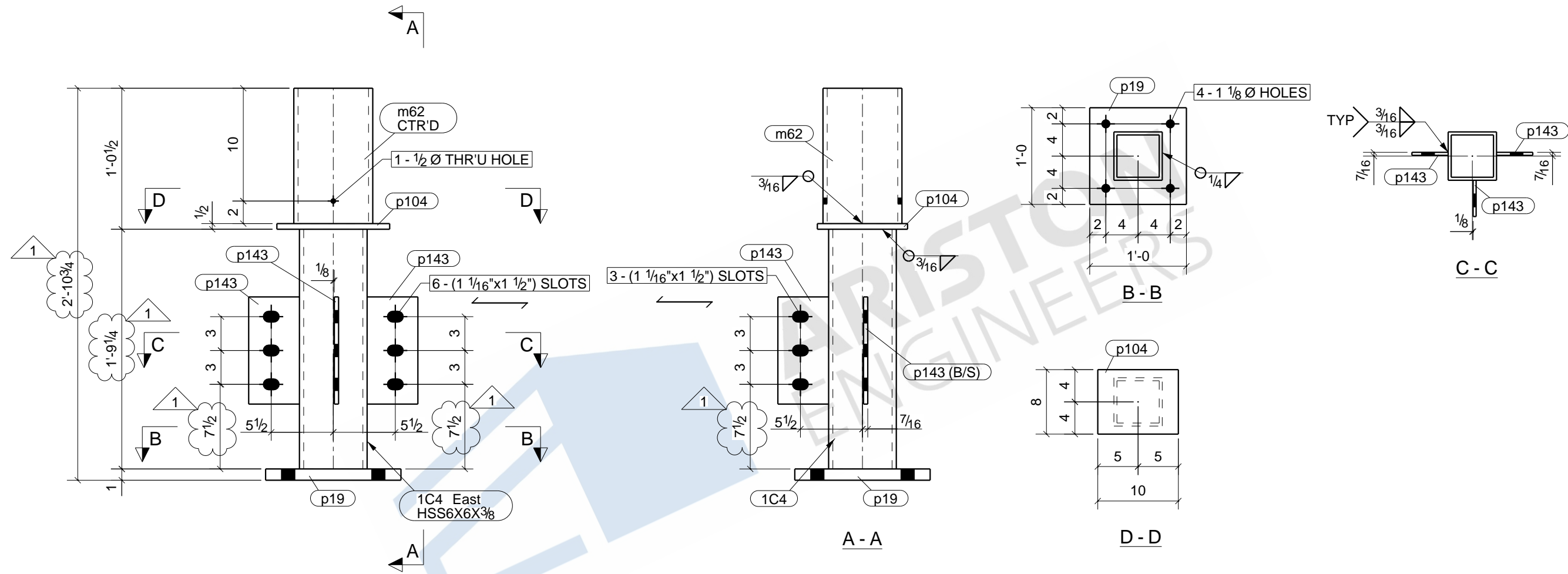

ONE - COLUMN - 1C4

BOLT : 3/4" A325N UNO		MATERIAL	
HOLES : 13/16" UNO		W SHAPES = A992	
WELD : E-70XX		TUBES = A500 (46 KSI)	
		SHOP PREP PER SPECS	
FINISH : NO PAINT			
REVISIONS		ITEM	1C4 - COLUMN
NO	DESCRIPTION	DATE	JDA MADISON SELF STORAGE
		ARCH	
		CONTR	
DWN : ASM		DATE:	CHK'D:ARP
JOB#			DATE:
		DWG NO.	1C4

Tekla structures

LINE	GRADE	SCOPE	QTY	DESCRIPTION	LENGTH	MARK	REMARK
	-		1	COLUMN		1C5	NO PAINT
	A500-GR.C		1	HSS6X6X3/8	1'-9 1/4"	1C5	
	A500-GR.C		1	HSS7X7X3/8	1'-0"	m62	
	A36		1	PL1"x12"	1'-0"	p19	
	A36		1	PL3/8"x3 1/2"	0'-6"	p23	
	A36		1	PL1/2"x8"	0'-10"	p104	
	A36		2	PL3/8"x4 1/2"	0'-9 1/2"	p143	
	-		4	1"Ø SIMPSON BOLT	0'-8"		FIELD BOLT

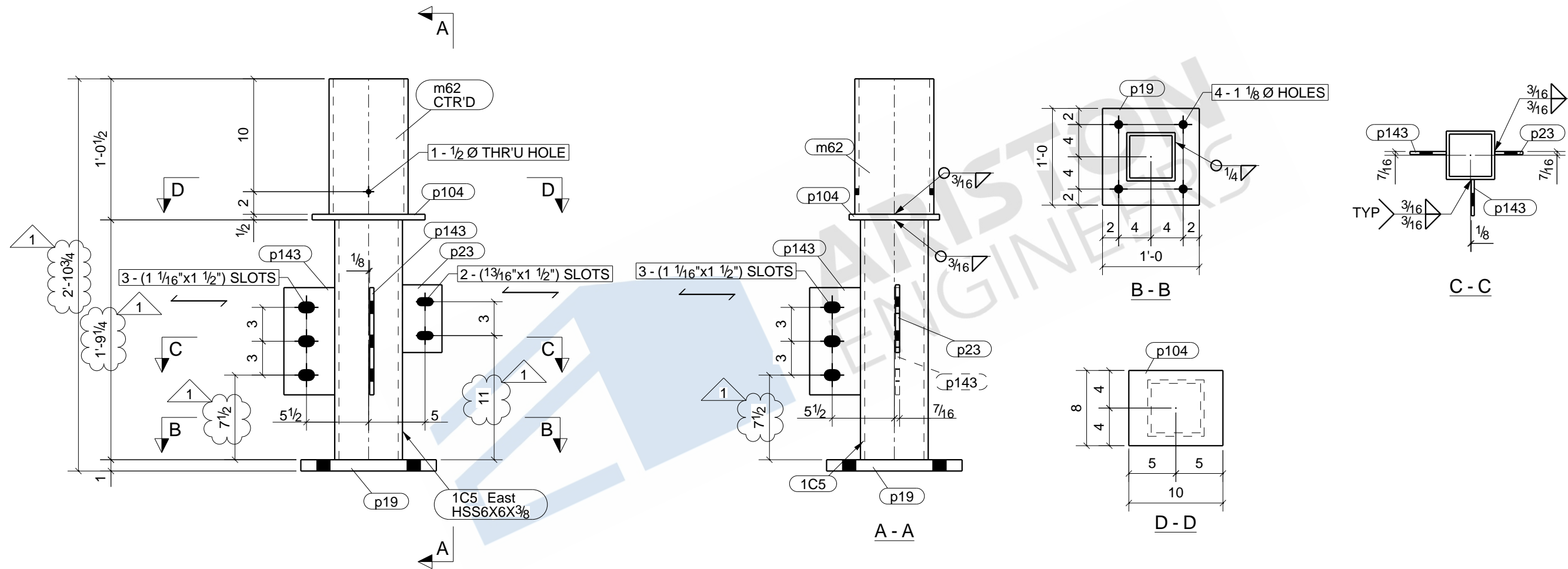

ONE - COLUMN - 1C5

BOLT : 3/4" A325N UNO		MATERIAL	
HOLES : 13/16" UNO		W SHAPES = A992	
WELD : E-70XX		TUBES = A500 (46 KSI)	
FINISH : NO PAINT		SHOP PREP PER SPECS	
REVISIONS		ITEM	1C5 - COLUMN
NO	DESCRIPTION	DATE	JDA MADISON SELF STORAGE
		ARCH	
		CONTR	
DWN : ASM		DATE:	CHK'D:ARP
JOB#			DATE:
		DWG NO.	1C5

LINE	GRADE	SCOPE	QTY	DESCRIPTION	LENGTH	MARK	REMARK
	-		1	COLUMN		2C1	NO PAINT
	A500-GR.C		1	HSS5X5X3/8	10'-3 1/2"	2C1	
	A500-GR.C		1	HSS6X6X5/8	1'-0"	m143	
	A36		2	PL3/8"x3 1/2"	0'-6"	p23	
	A36		1	PL1/2"x8"	0'-10"	p104	

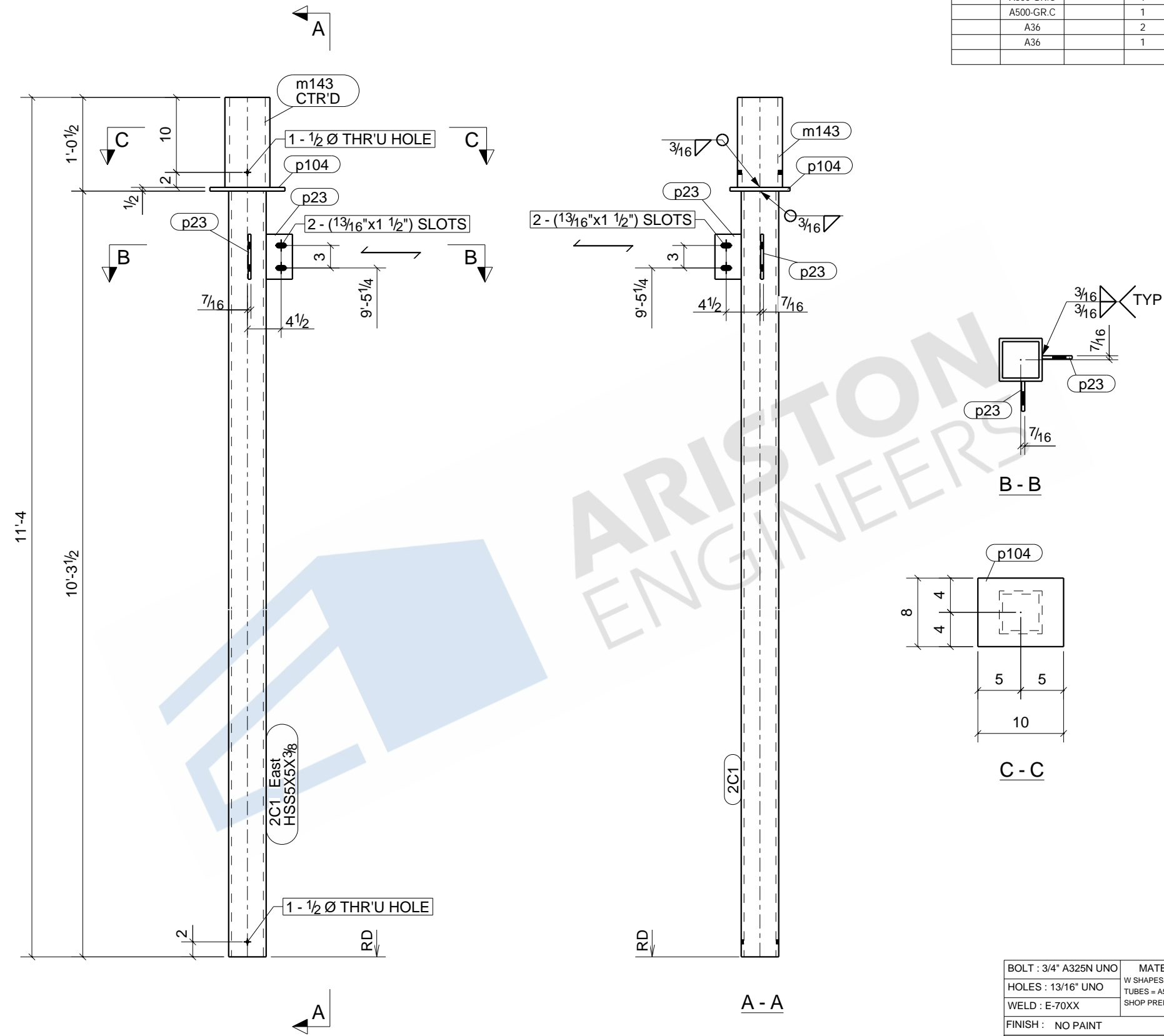

ONE - COLUMN - 2C1

BOLT : 3/4" A325N UNO		MATERIAL	
HOLES : 13/16" UNO		W SHAPES = A992	
WELD : E-70XX		TUBES = A500 (46 KSI)	
FINISH : NO PAINT		SHOP PREP PER SPECS	
REVISIONS		ITEM	2C1 - COLUMN
NO	DESCRIPTION	DATE	JDA MADISON SELF STORAGE
		ARCH	
		CONTR	
DWN : ASM		DATE:	CHK'D: NSP
JOB#			DATE:
		DWG NO.	2C1

LINE	GRADE	SCOPE	QTY	DESCRIPTION	LENGTH	MARK	REMARK
	-		1	COLUMN		2C2	NO PAINT
	A500-GR.C		1	HSS5X5X3/8	10'-3 1/2"	2C2	
	A500-GR.C		1	HSS6X6X5/8	1'-0"	m143	
	A36		3	PL3/8"x3 1/2"	0'-6"	p23	
	A36		1	PL1/2"x8"	0'-10"	p104	

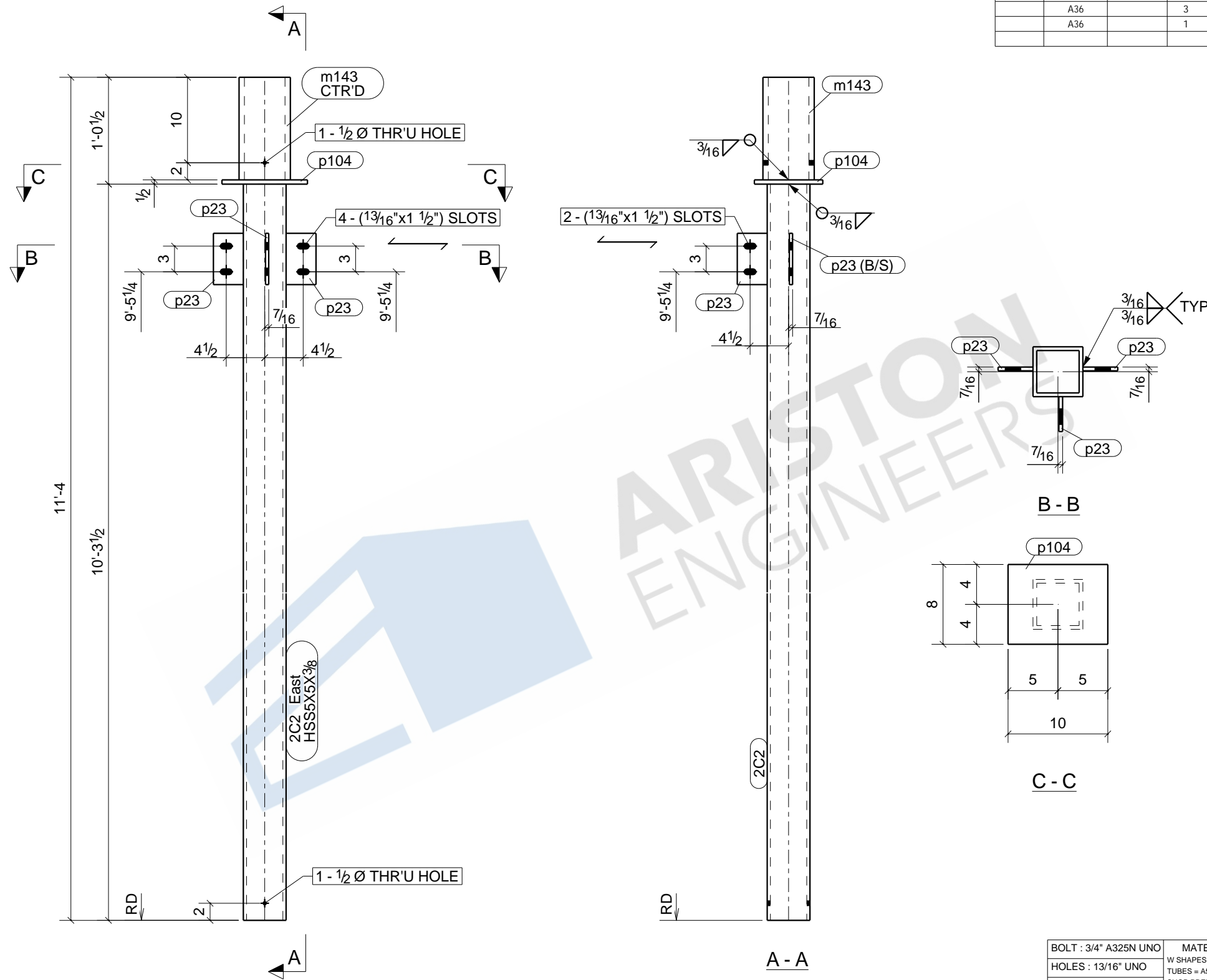

ONE - COLUMN - 2C2

BOLT : 3/4" A325N UNO		MATERIAL	
HOLES : 13/16" UNO		W SHAPES = A992	
WELD : E-70XX		TUBES = A500 (46 KSI)	
FINISH : NO PAINT		SHOP PREP PER SPECS	
REVISIONS		ITEM	2C2 - COLUMN
NO	DESCRIPTION	DATE	JDA MADISON SELF STORAGE
		ARCH	
		CONTR	
DWN : ASM		DATE:	CHK'D: NSP
JOB#			DATE:
		DWG NO.	2C2

LINE	GRADE	SCOPE	QTY	DESCRIPTION	LENGTH	MARK	REMARK
	-		8	COLUMNS		2C3	NO PAINT
	A500-GR.C		8	HSS5X5X3/8	10'-3 1/2"	2C3	
	A500-GR.C		8	HSS6X6X5/8	1'-0"	m143	
	A36		24	PL3/8"x3 1/2"	0'-6"	p23	
	A36		8	PL1/2"x8"	0'-10"	p104	

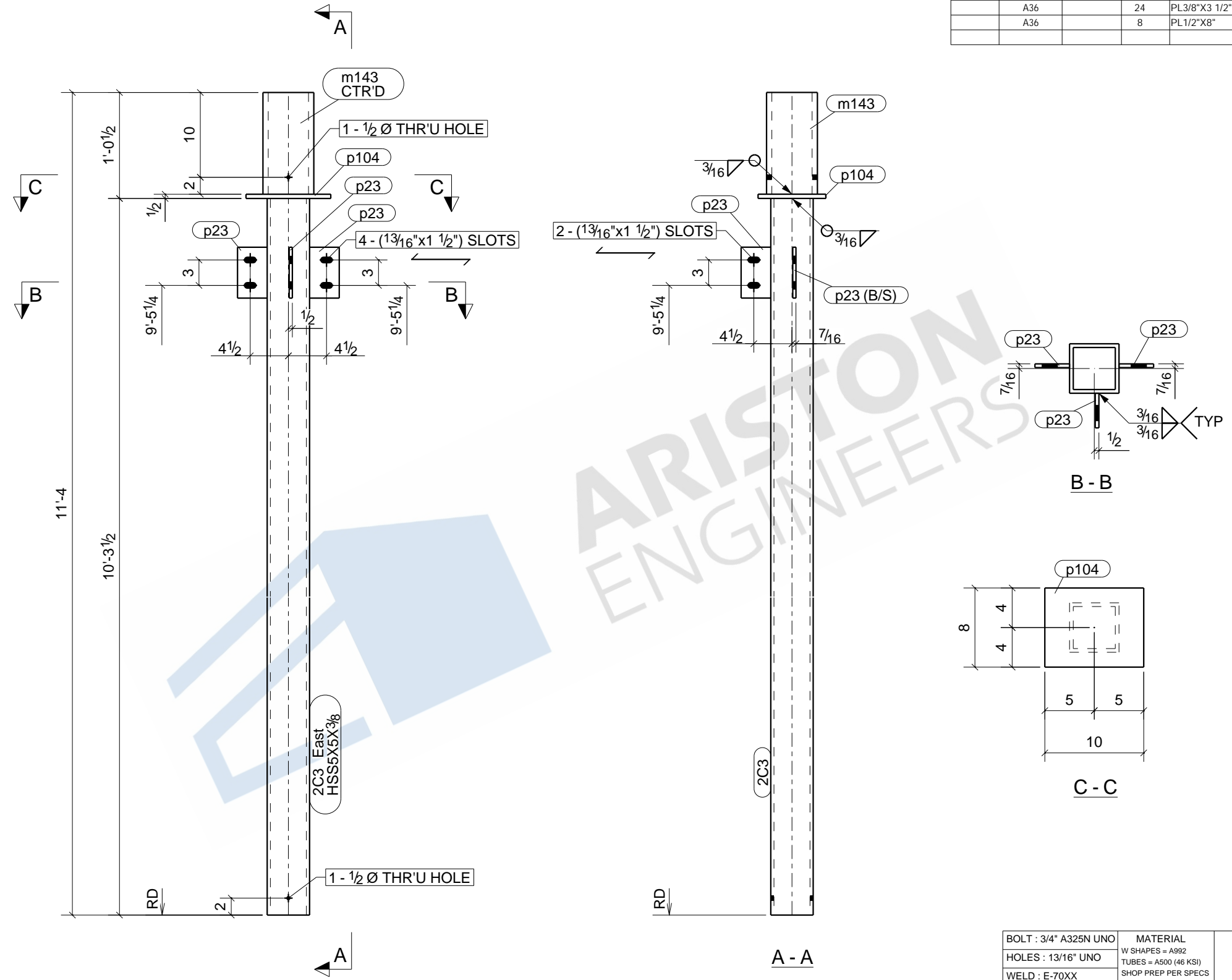

8 - COLUMNS - 2C3

BOLT : 3/4" A325N UNO		MATERIAL	
HOLES : 13/16" UNO		W SHAPES = A992	
WELD : E-70XX		TUBES = A500 (46 KSI)	
FINISH : NO PAINT		SHOP PREP PER SPECS	
REVISIONS		ITEM	2C3 - COLUMN
NO	DESCRIPTION	DATE	JDA MADISON SELF STORAGE
		ARCH	
		CONTR	
DWN : ASM		DATE:	CHK'D: NSP
JOB#			DATE:
		DWG NO.	2C3

LINE	GRADE	SCOPE	QTY	DESCRIPTION	LENGTH	MARK	REMARK
	-		1	COLUMN		2C4	NO PAINT
	A500-GR.C		1	HSS5X5X3/8	10'-8 3/4"	2C4	
	A500-GR.C		1	HSS6X6X5/8	1'-0"	m143	
	A36		2	PL3/8"x3 1/2"	0'-6"	p23	
	A36		1	PL1/2"x8"	0'-10"	p104	

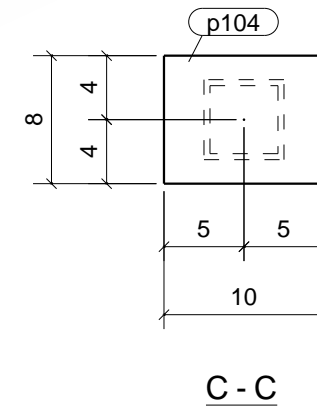
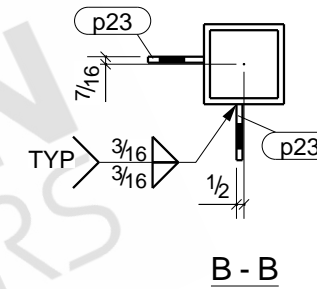
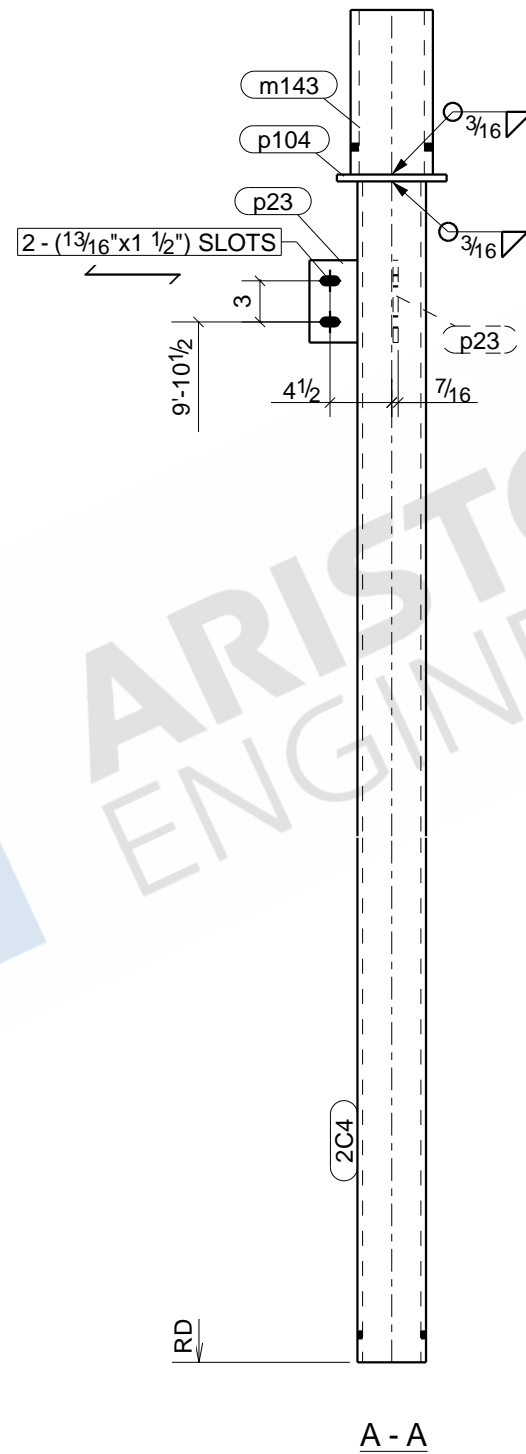
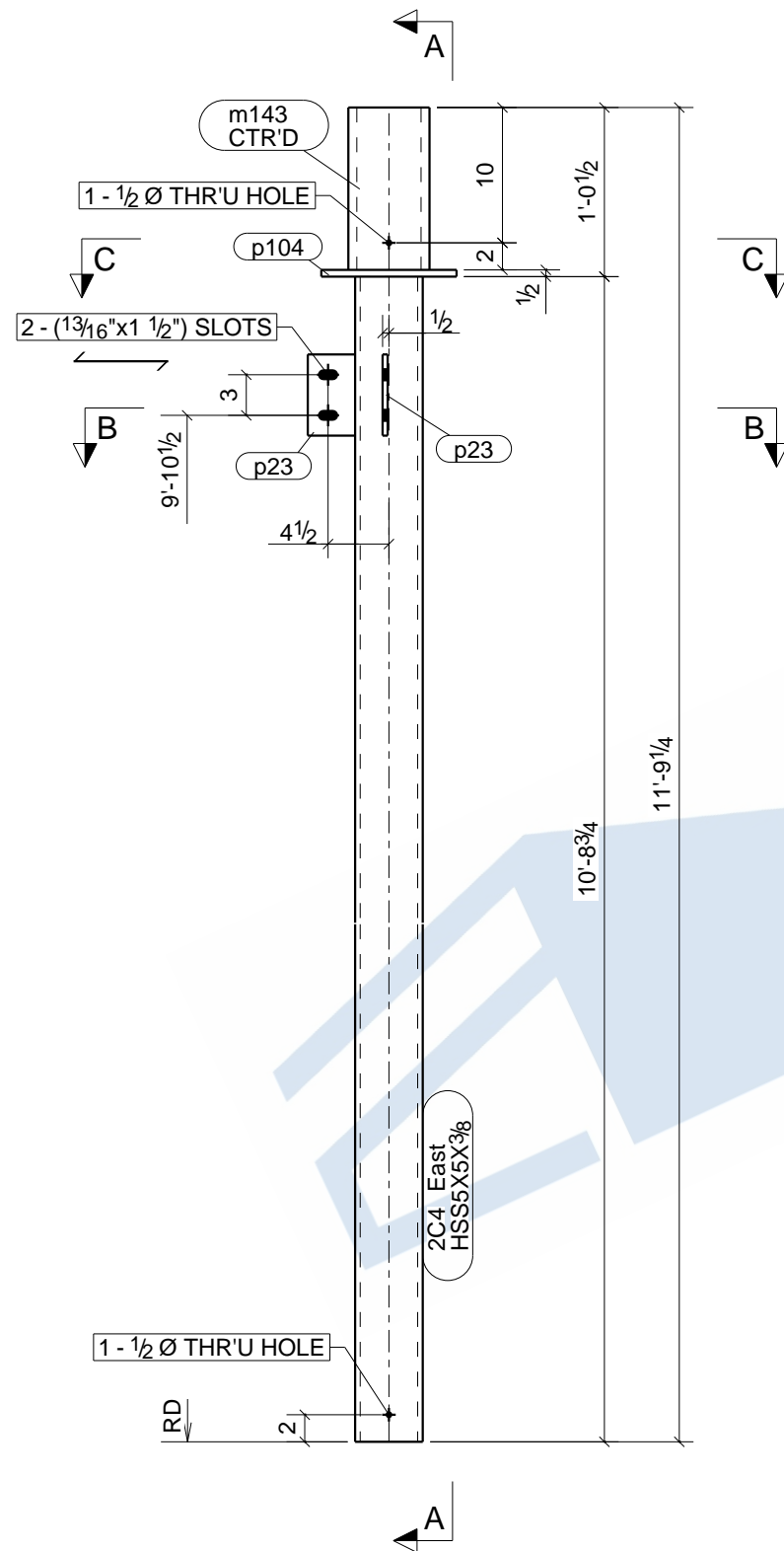

ONE - COLUMN - 2C4

BOLT : 3/4" A325N UNO		MATERIAL	
HOLES : 13/16" UNO		W SHAPES = A992	
WELD : E-70XX		TUBES = A500 (46 KSI)	
FINISH : NO PAINT		SHOP PREP PER SPECS	
REVISIONS		ITEM	2C4 - COLUMN
NO	DESCRIPTION	DATE	JDA MADISON SELF STORAGE
		ARCH	
		CONTR	
DWN : ASM		DATE:	CHK'D: NSP
JOB#			DATE:
		DWG NO.	2C4

LINE	GRADE	SCOPE	QTY	DESCRIPTION	LENGTH	MARK	REMARK
	-		1	COLUMN		2C5	NO PAINT
	A500-GR.C		1	HSS5X5X3/8	10'-3 1/2"	2C5	
	A500-GR.C		1	HSS6X6X5/8	1'-0"	m143	
	A36		2	PL3/8"x3 1/2"	0'-6"	p23	
	A36		1	PL1/2"x8"	0'-10"	p104	

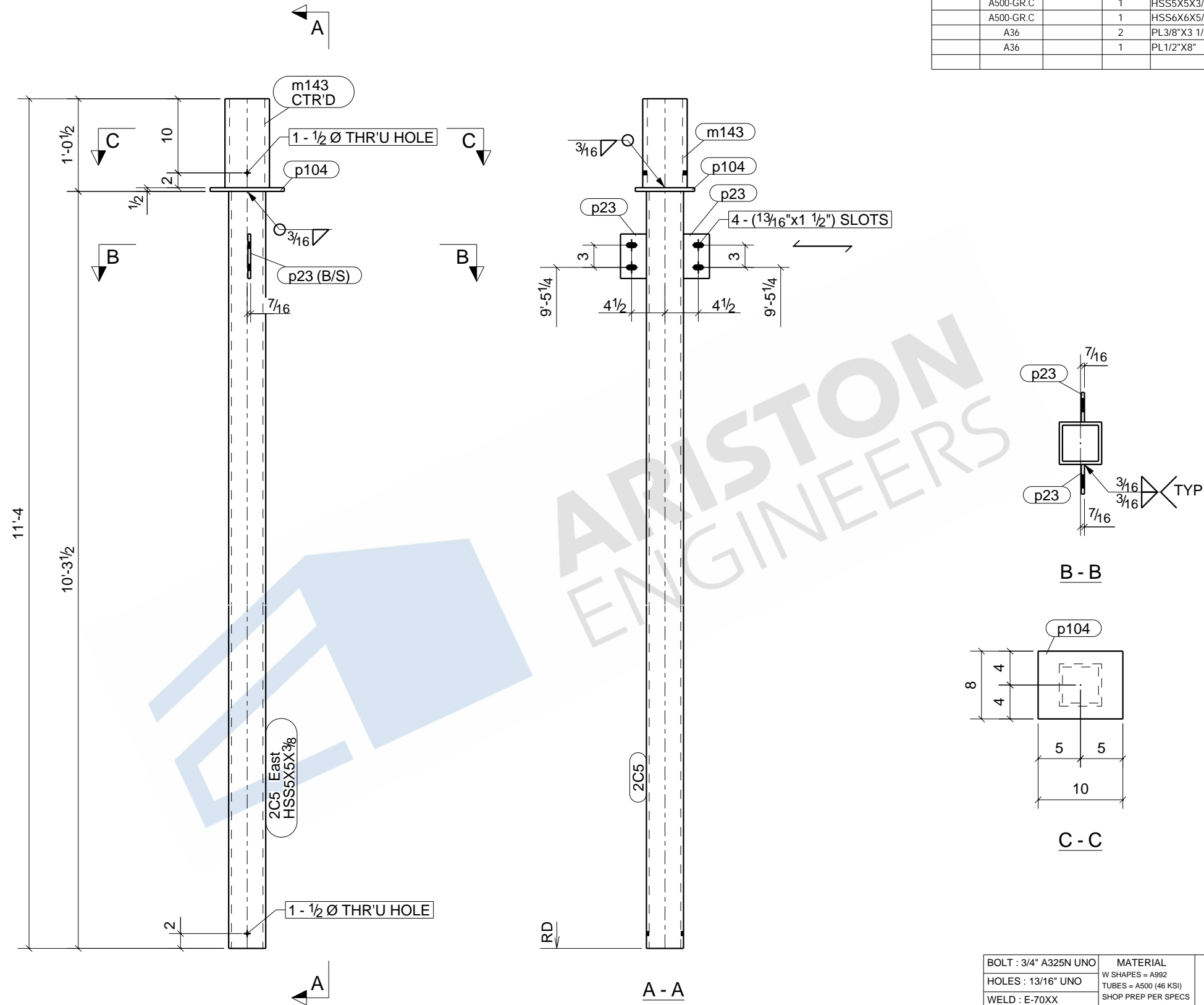

ONE - COLUMN - 2C5

BOLT : 3/4" A325N UNO		MATERIAL	
HOLES : 13/16" UNO		W SHAPES = A992	
WELD : E-70XX		TUBES = A500 (46 KSI)	
FINISH : NO PAINT		SHOP PREP PER SPECS	
REVISIONS		ITEM	2C5 - COLUMN
NO	DESCRIPTION	DATE	JDA MADISON SELF STORAGE
		ARCH	
		CONTR	
DWN : ASM		DATE:	CHK'D: NSP
JOB#			DATE:
		DWG NO.	2C5

LINE	GRADE	SCOPE	QTY	DESCRIPTION	LENGTH	MARK	REMARK
-	-	-	1	DECK ANGLE		1DA1	NO PAINT
A36	-	-	1	L5X5X3/8	16'-7"	1DA1	
-	-	-	7	3/4"Ø EXPANSION ANCHOR BOLT	0'-7"		FIELD BOLT

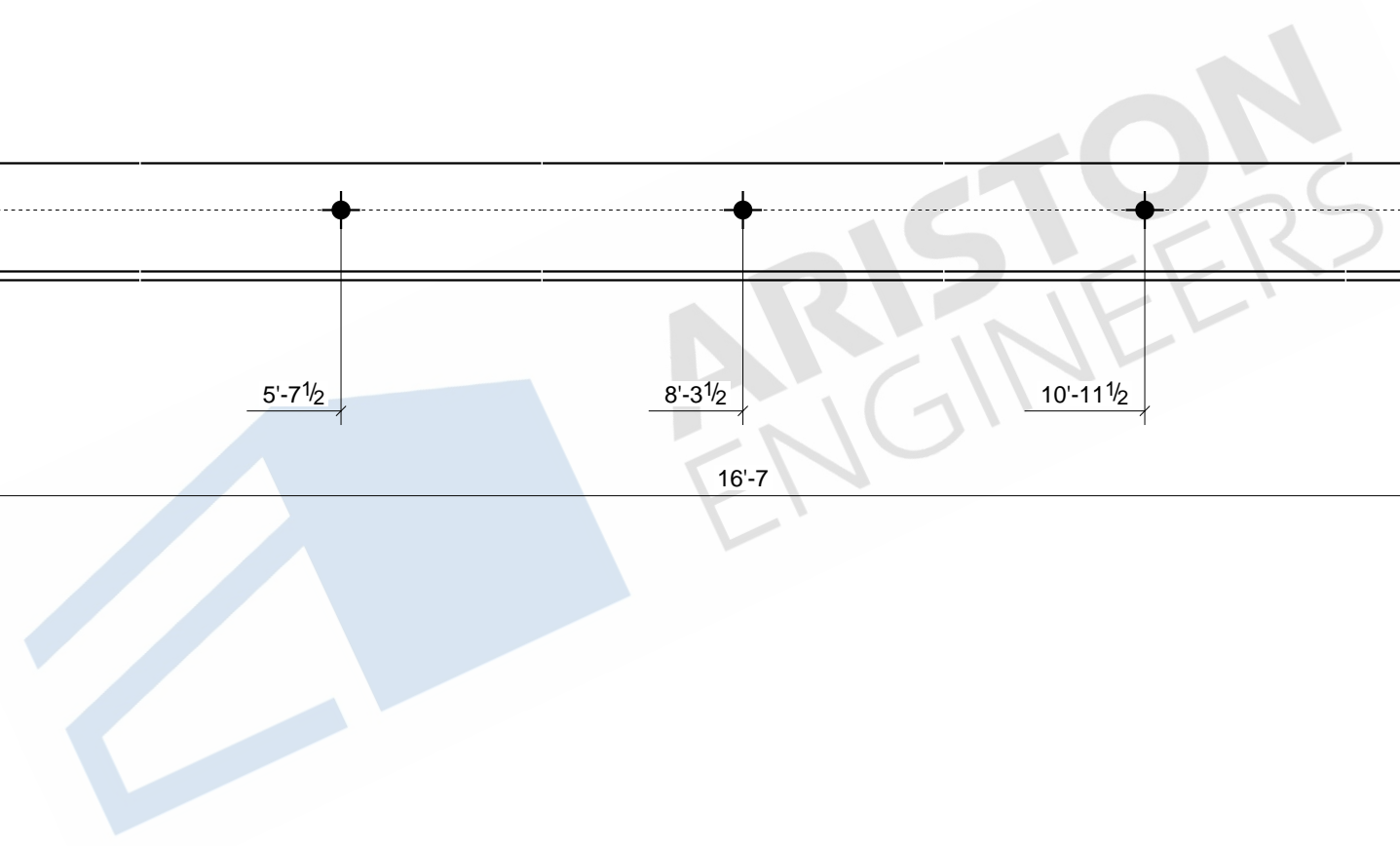
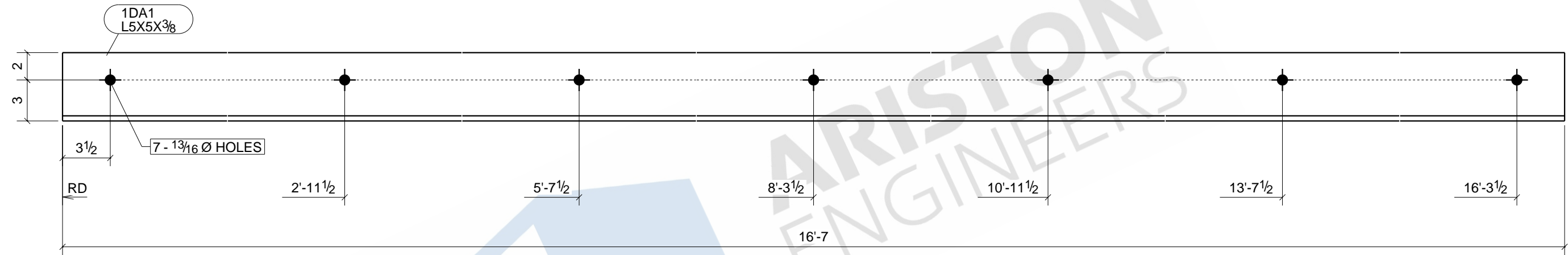

ONE - DECK ANGLE - 1DA1

BOLT : 3/4" A325N UNO		MATERIAL	
HOLES : 13/16" UNO		W SHAPES = A992 TUBES = A500 (46 KSI) SHOP PREP PER SPECS	
WELD : E-70XX		FINISH : NO PAINT	
REVISIONS		ITEM	1DA1 - DECK ANGLE
NO	DESCRIPTION	DATE	JDA MADISON SELF STORAGE
		ARCH	
		CONTR	
DWN : ASM		DATE:	CHK'D: NSP
JOB#			DATE:
		DWG NO.	1DA1

LINE	GRADE	SCOPE	QTY	DESCRIPTION	LENGTH	MARK	REMARK
-	-	-	1	DECK ANGLE		1DA2	NO PAINT
A36	-	-	1	L5X5X3/8	15'-9"	1DA2	
-	-	-	7	3/4"Ø EXPANSION ANCHOR BOLT	0'-7"		FIELD BOLT

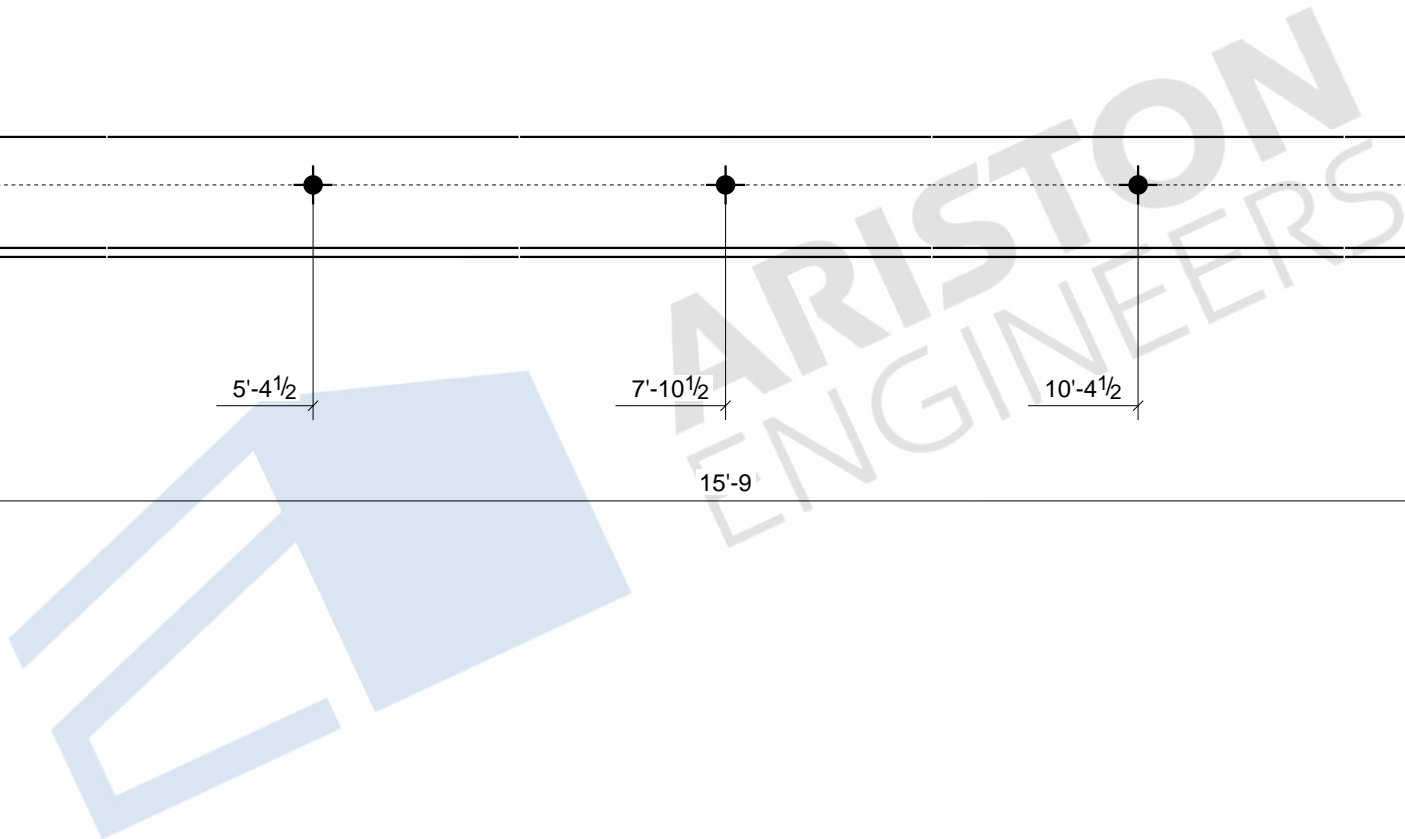
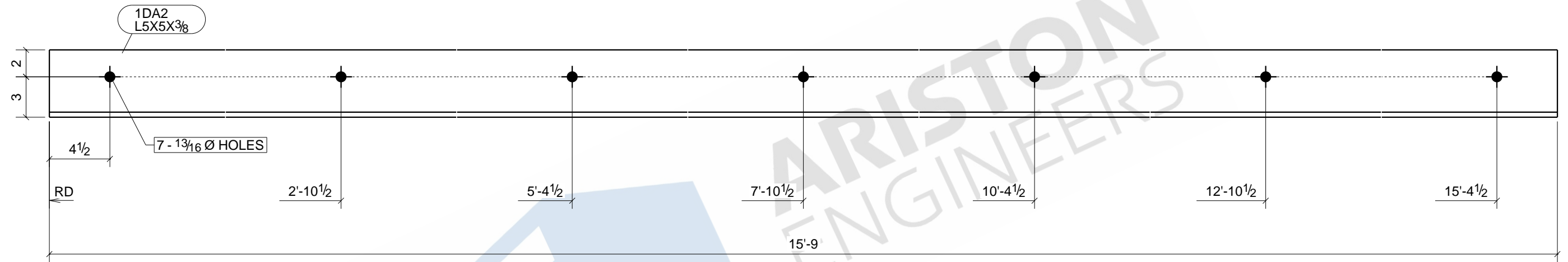

Tekla structures

ONE - DECK ANGLE - 1DA2

BOLT : 3/4" A325N UNO		MATERIAL	
HOLES : 13/16" UNO		W SHAPES = A992 TUBES = A500 (46 KSI) SHOP PREP PER SPECS	
WELD : E-70XX		FINISH : NO PAINT	
REVISIONS		ITEM	1DA2 - DECK ANGLE
NO	DESCRIPTION	DATE	JDA MADISON SELF STORAGE
		ARCH	
		CONTR	
DWN : ASM		DATE:	CHK'D: NSP
JOB#			DATE:
		DWG NO.	1DA2

LINE	GRADE	SCOPE	QTY	DESCRIPTION	LENGTH	MARK	REMARK
-			1	DIAMOND PLATE		S-DP1	SHOP PRIME
A36			1	CP3/16"X43 3/4"	4'-3 7/8"	S-DP1	

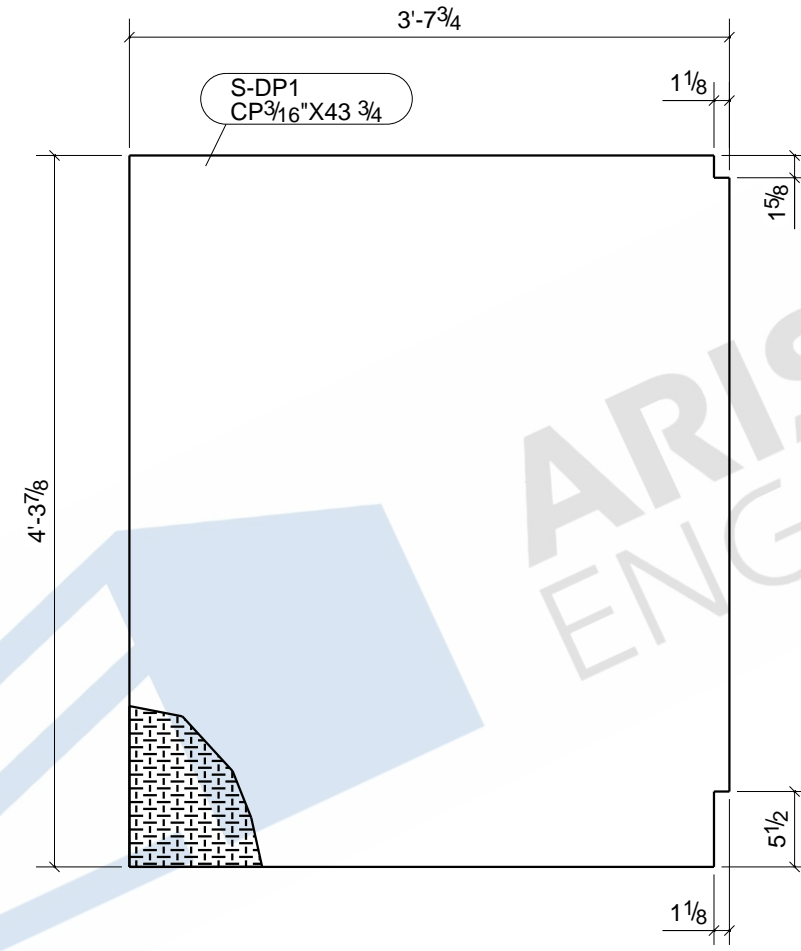

ONE - DIAMOND PLATE - S-DP1

BOLT : 3/4" A325N UNO		MATERIAL	
HOLES : 13/16" UNO		W SHAPES = A992 TUBES = A500 (46 KSI) SHOP PREP PER SPECS	
WELD : E-70XX		FINISH : SHOP PRIME	
REVISIONS		ITEM	S-DP1 - DIAMOND PLATE
NO	DESCRIPTION	DATE	JOB JDA MADISON SELF STORAGE
		ARCH	
		CONTR	
		DWN : ASM	DATE:
		CHK'D: NSP	DATE:
		JOB#	DWG NO. S-DP1

LINE	GRADE	SCOPE	QTY	DESCRIPTION	LENGTH	MARK	REMARK
-	-	-	1	EGRESS GATE		S-EG201	SHOP PRIME
A53			1	PIPE 1-1/4 SCH40	6'-10 11/16"	S-EG201	
A53			1	SELF CLOSING HINGE BOI			
A53			1	SELF CLOSING HINGE BOI			
A53			1	HSS 1-1/2 X 1-1/2 X 1/8	2'-1 3/4"	m307	
A36			2	PL 1/4" X 3"	0'-9"	p260	
A36			2	PL 1/8" X 1 1/2"	0'-1 1/2"	p262	
-			4	3/4" Ø EPOXY_ANC BOLT	0'-4 3/4"		FIELD BOLT

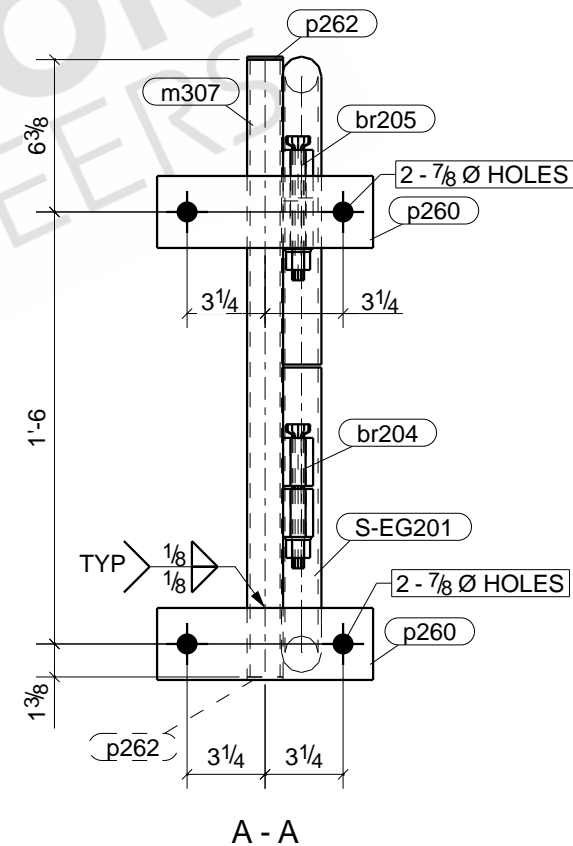
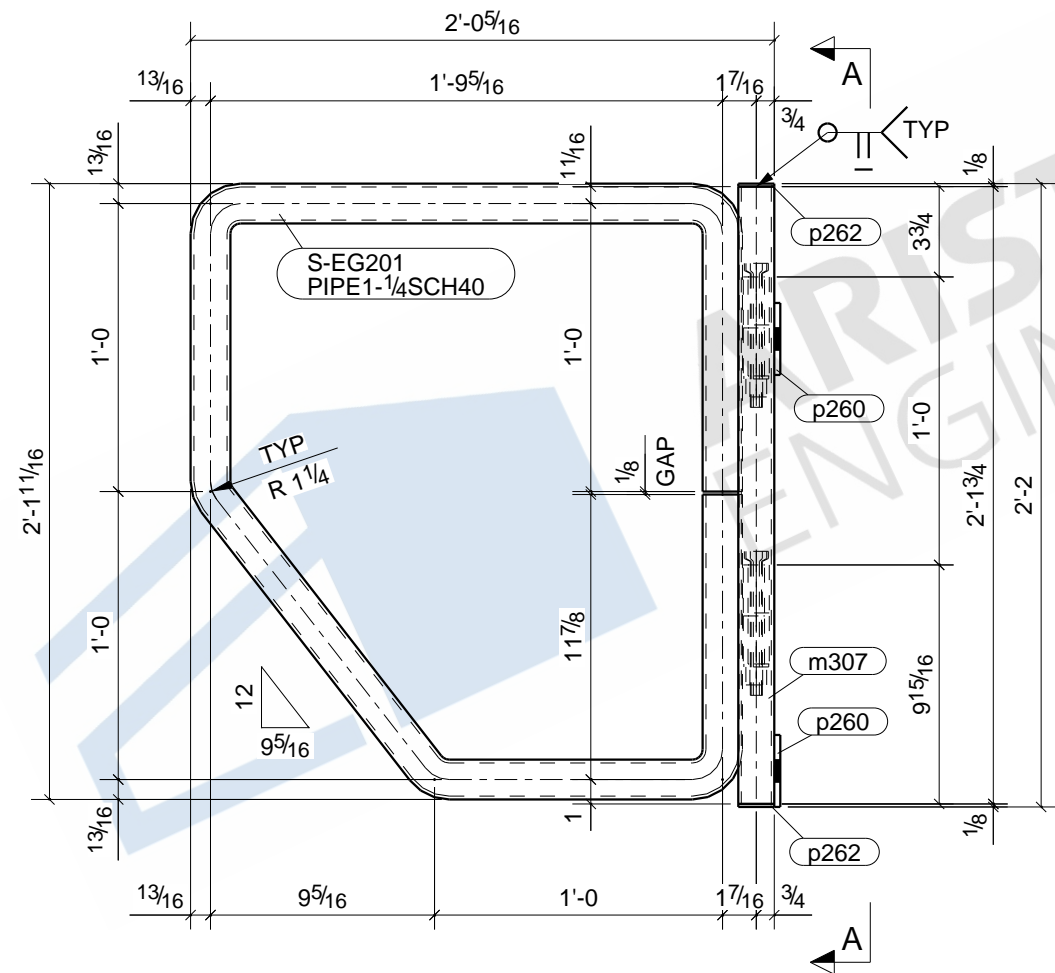
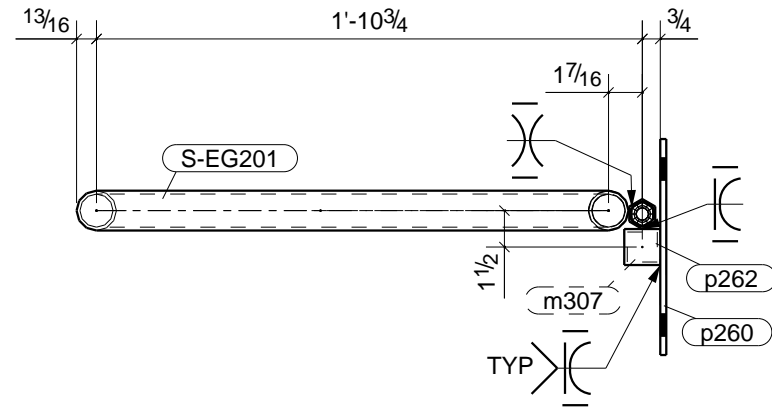

ONE - EGRESS GATE - S-EG201

BOLT : 3/4" A325N UNO		MATERIAL	
HOLES : 13/16" UNO		W SHAPES = A992	
WELD : E-70XX		TUBES = A500 (46 KSI)	
FINISH : SHOP PRIME		SHOP PREP PER SPECS	
REVISIONS		ITEM	S-EG201- EGRESS GATE
NO	DESCRIPTION	DATE	JDA MADISON SELF STORAGE
		ARCH	
		CONTR	
DWN : ASM		DATE:	CHK'D: NSP
JOB#			DATE:
		DWG NO.	S-EG201

LINE	GRADE	SCOPE	QTY	DESCRIPTION	LENGTH	MARK	REMARK
-	-	-	4	HANGERS		2HG1	NO PAINT
A36			4	C6X8.2	3'-5 1/4"	2HG1	
-	-	-	12	3/4"Ø A325N BOLT	0'-1 3/4"		FIELD BOLT

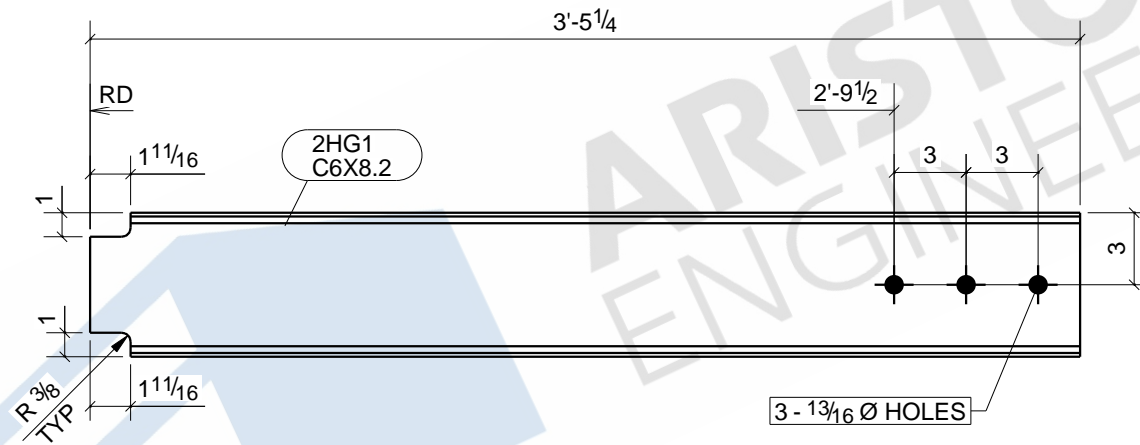

4 - HANGERS - 2HG1

BOLT : 3/4" A325N UNO		MATERIAL	
HOLES : 13/16" UNO		W SHAPES = A992 TUBES = A500 (46 KSI) SHOP PREP PER SPECS	
WELD : E-70XX		FINISH : NO PAINT	
REVISIONS		ITEM	2HG1 - HANGER
NO	DESCRIPTION	DATE	JDA MADISON SELF STORAGE
		ARCH	
		CONTR	
DWN : ASM	DATE:	CHK'D: NSP	DATE:
JOB#		DWG NO.	2HG1

LINE	GRADE	SCOPE	QTY	DESCRIPTION	LENGTH	MARK	REMARK
-	-	-	5	HANGERS		2HG2	NO PAINT
A36			5	C6X8.2	6'-9 5/16"	2HG2	
-	-	-	15	3/4"Ø A325N BOLT	0'-1 3/4"		FIELD BOLT

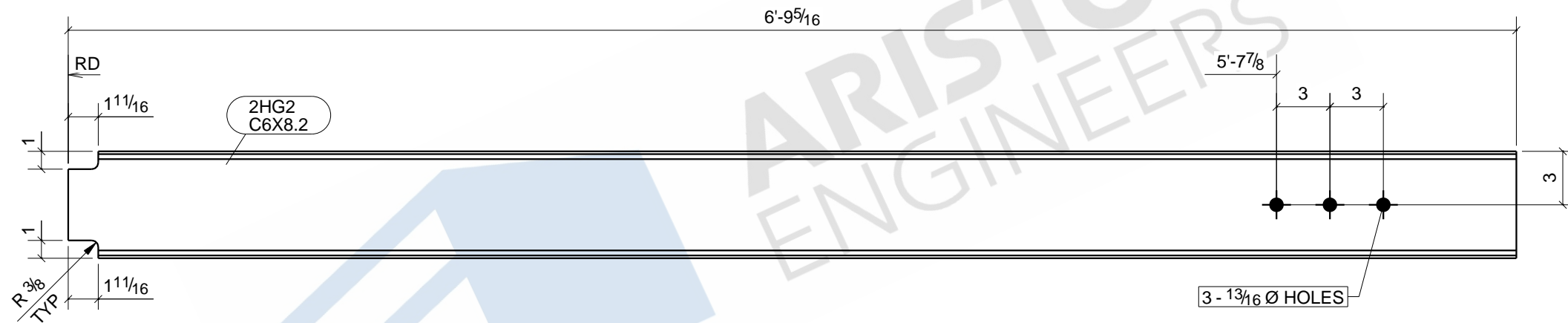

5 - HANGERS - 2HG2

BOLT : 3/4" A325N UNO		MATERIAL	
HOLES : 13/16" UNO		W SHAPES = A992	
WELD : E-70XX		TUBES = A500 (46 KSI)	
FINISH : NO PAINT		SHOP PREP PER SPECS	
REVISIONS		ITEM	2HG2 - HANGER
NO	DESCRIPTION	DATE	JDA MADISON SELF STORAGE
		ARCH	
		CONTR	
DWN : ASM		DATE:	CHK'D: NSP
JOB#			DATE:
		DWG NO.	2HG2

LINE	GRADE	SCOPE	QTY	DESCRIPTION	LENGTH	MARK	REMARK
	-		4	KICKER_BRACES		2KB1	NO PAINT
	A36		4	L3X3X3/8	10'-6"	2KB1	

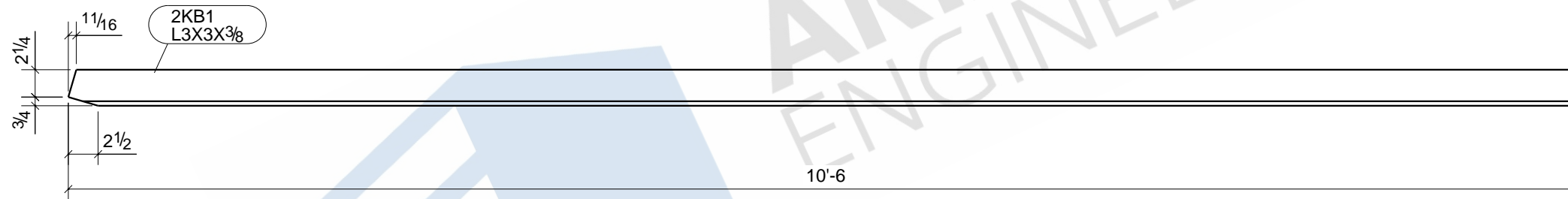

4 - KICKER_BRACES - 2KB1

BOLT : 3/4" A325N UNO		MATERIAL	
HOLES : 13/16" UNO		W SHAPES = A992 TUBES = A500 (46 KSI) SHOP PREP PER SPECS	
WELD : E-70XX		FINISH : NO PAINT	
REVISIONS		ITEM	2KB1 - KICKER_BRACE
NO	DESCRIPTION	DATE	JDA MADISON SELF STORAGE
		ARCH	
		CONTR	
		DWN : ASM	DATE:
		CHK'D: NSP	DATE:
		JOB#	DWG NO. 2KB1

LINE	GRADE	SCOPE	QTY	DESCRIPTION	LENGTH	MARK	REMARK
	-		5	KICKER_BRACES		2KB2	NO PAINT
	A36		5	L3X3X3/8	9'-1 7/8"	2KB2	

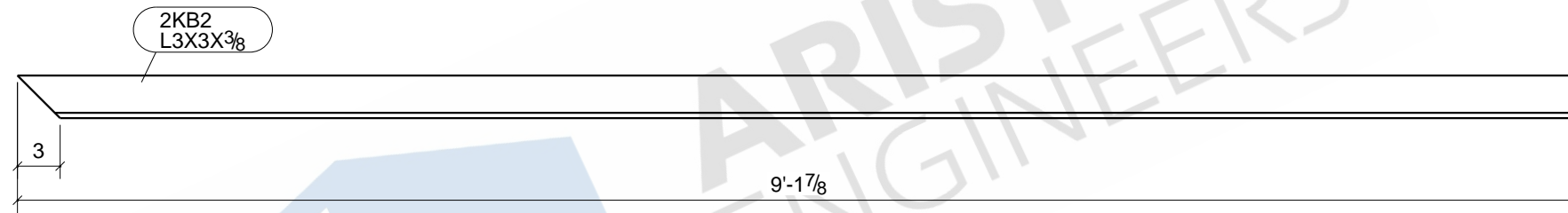

5 - KICKER_BRACES - 2KB2

BOLT : 3/4" A325N UNO		MATERIAL	
HOLES : 13/16" UNO		W SHAPES = A992 TUBES = A500 (46 KSI) SHOP PREP PER SPECS	
WELD : E-70XX		FINISH : NO PAINT	
REVISIONS		ITEM	2KB2 - KICKER_BRACE
NO	DESCRIPTION	DATE	JDA MADISON SELF STORAGE
		ARCH	
		CONTR	
DWN : ASM		DATE:	CHK'D: NSP
JOB#			DATE:
		DWG NO.	2KB2

LINE	GRADE	SCOPE	QTY	DESCRIPTION	LENGTH	MARK	REMARK
	-		1	LADDER		LD1	SHOP PRIME
A36			1	PL3/8"X2 1/2"	8'-6 3/16"	LD1	
A36			1	PL3/8"X2 1/2"	8'-6 3/16"	bpl25	
A36			8	PL3/8"X2 1/2"	0'-10 1/2"	bpl26	
A36			5	ROD3/4"	1'-8 1/2"	m168	
-			8	5/8"Ø HILTI-KB3 BOLT	0'-5"		FIELD BOLT

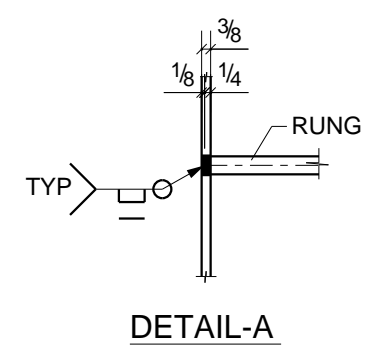
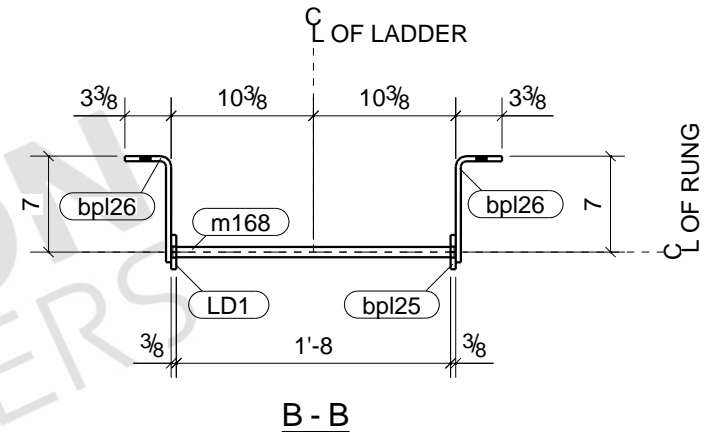
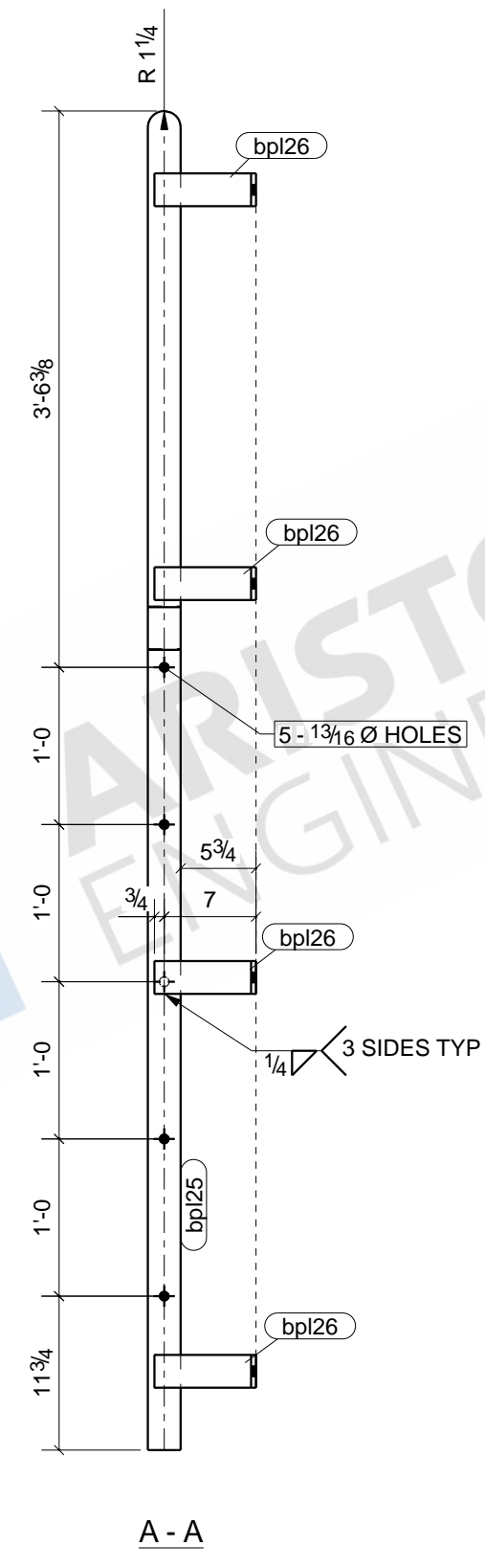
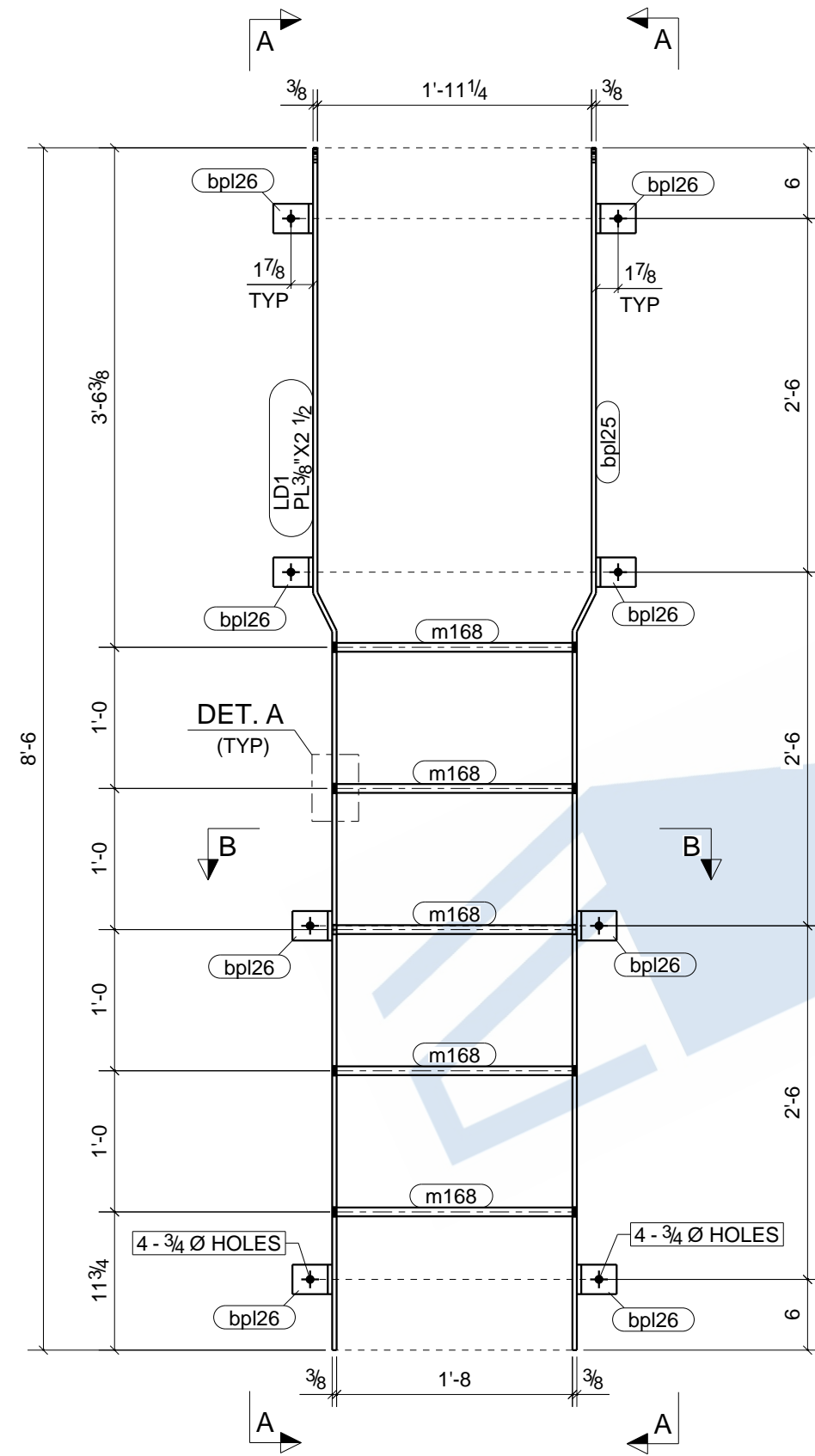

ONE - LADDER - LD1

BOLT : 3/4" A325N UNO		MATERIAL	
HOLES : 13/16" UNO		W SHAPES = A992	
WELD : E-70XX		TUBES = A500 (46 KSI)	
FINISH : SHOP PRIME		SHOP PREP PER SPECS	
REVISIONS		ITEM	LD1 - LADDER
NO	DESCRIPTION	DATE	JDA MADISON SELF STORAGE
		ARCH	
		CONTR	
DWN : ASM		DATE:	CHK'D: NSP
JOB#			DATE:
		DWG NO.	LD1

LINE	GRADE	SCOPE	QTY	DESCRIPTION	LENGTH	MARK	REMARK
	-		36	LEVEL_PLATES		LP1	NO PAINT
	A36		36	PL1/4"X12"	1'-0"	LP1	

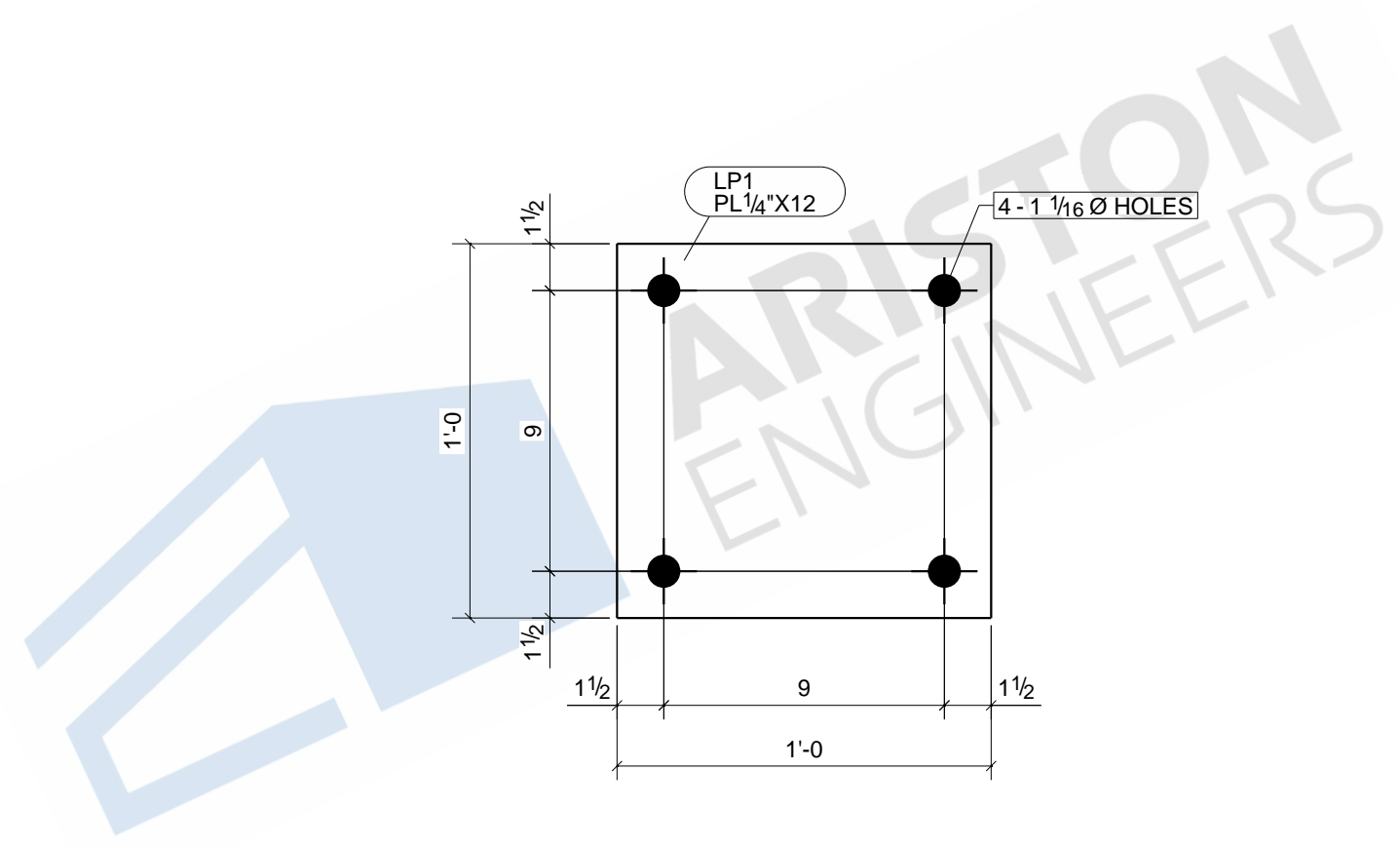
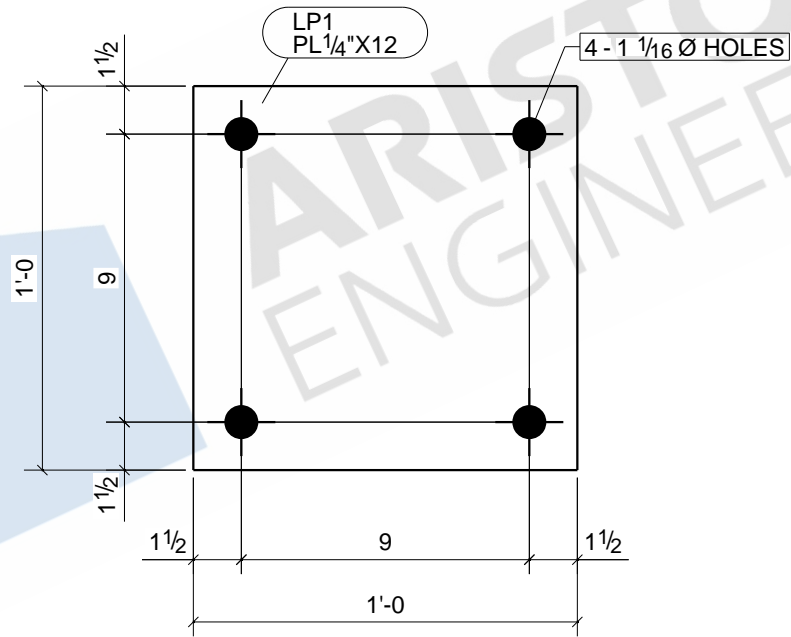

36 - LEVEL_PLATES - LP1

BOLT : 3/4" A325N UNO		MATERIAL	
HOLES : 13/16" UNO		W SHAPES = A992 TUBES = A500 (46 KSI) SHOP PREP PER SPECS	
WELD : E-70XX		FINISH : NO PAINT	
REVISIONS		ITEM	LP1 - LEVEL PLATE
NO	DESCRIPTION	DATE	JDA MADISON SELF STORAGE
		ARCH	
		CONTR	
		DWN : ASM	DATE:
		CHK'D: NSP	DATE:
		JOB#	DWG NO. LP1

LINE	GRADE	SCOPE	QTY	DESCRIPTION	LENGTH	MARK	REMARK
-			1	LINTEL ANGLE		1LA1	GALVANIZED
A36			1	L5X3-1/2X5/16	4'-8"	1LA1	
A36			1	L5X3-1/2X5/16	4'-8"	a2	

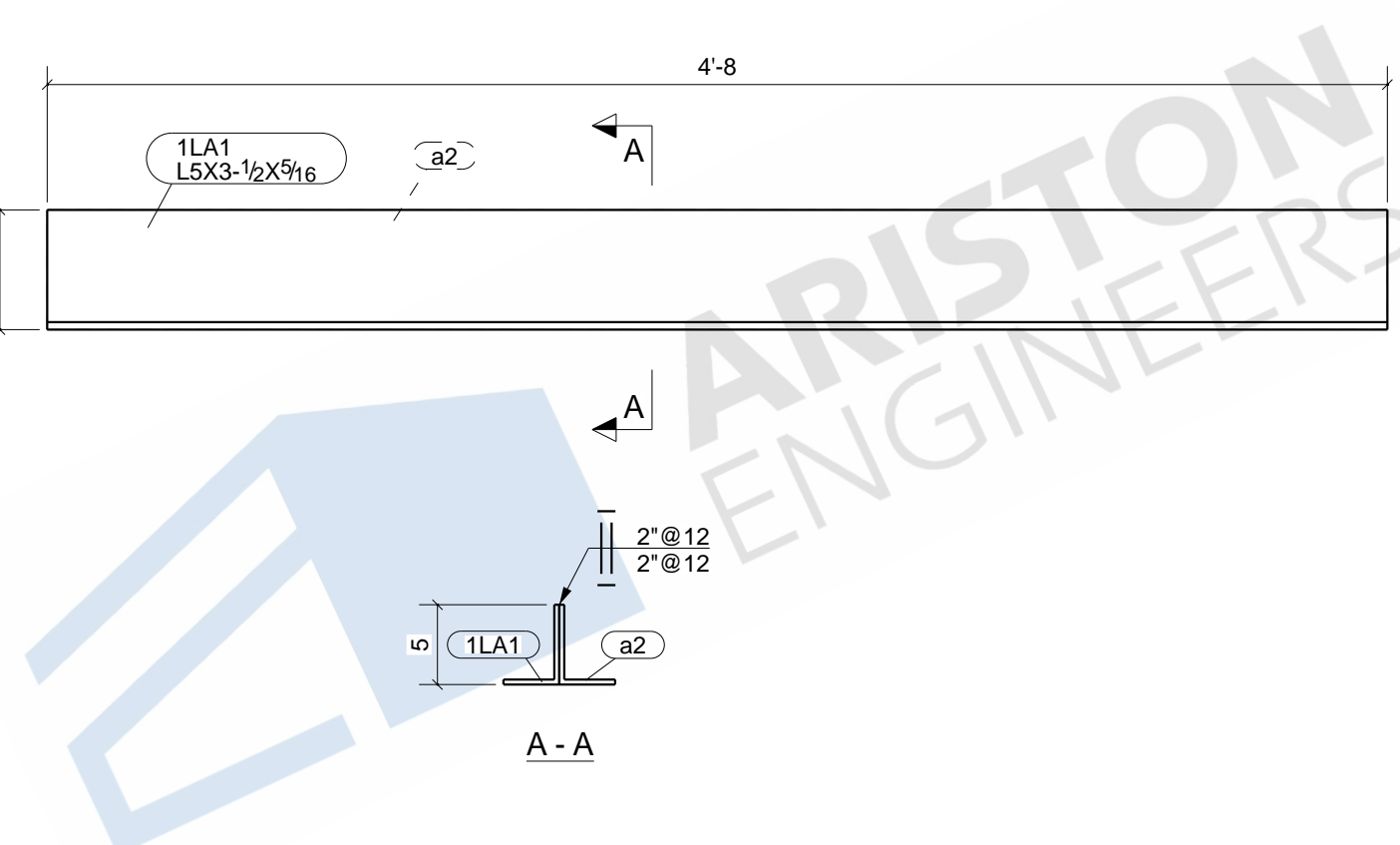
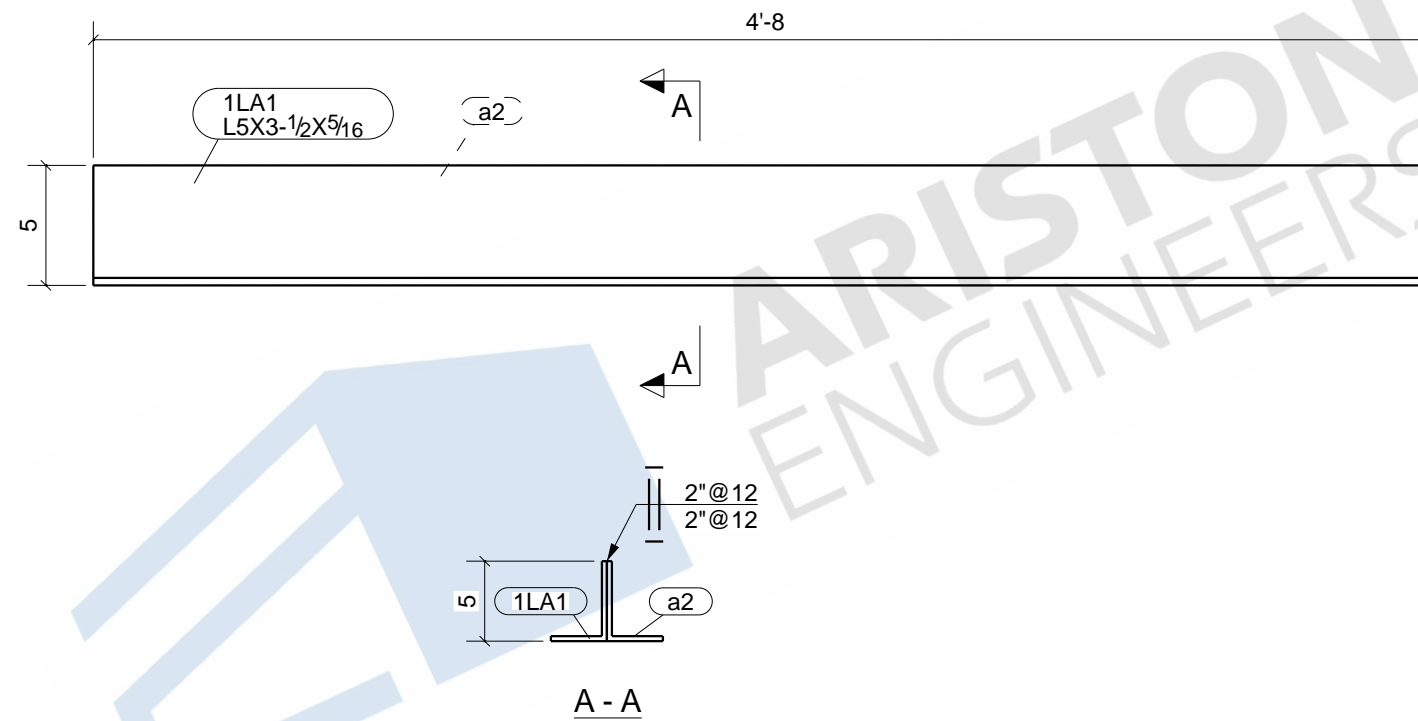

BOLT : 3/4" A325N UNO		MATERIAL	
HOLES : 13/16" UNO		W SHAPES = A992	
WELD : E-70XX		TUBES = A500 (46 KSI)	
FINISH : GALVANIZED		SHOP PREP PER SPECS	
REVISIONS		ITEM	1LA1 - LINTEL ANGLE
NO	DESCRIPTION	DATE	JDA MADISON SELF STORAGE
		ARCH	
		CONTR	
DWN : ASM		DATE:	CHK'D: NSP
JOB#			DATE:
		DWG NO.	1LA1

ONE - LINTEL ANGLE - 1LA1

LINE	GRADE	SCOPE	QTY	DESCRIPTION	LENGTH	MARK	REMARK
	-		10	LOOSE PLATES		MP3	NO PAINT
	A36		10	PL3/8"X12"	2'-3 1/2"	MP3	

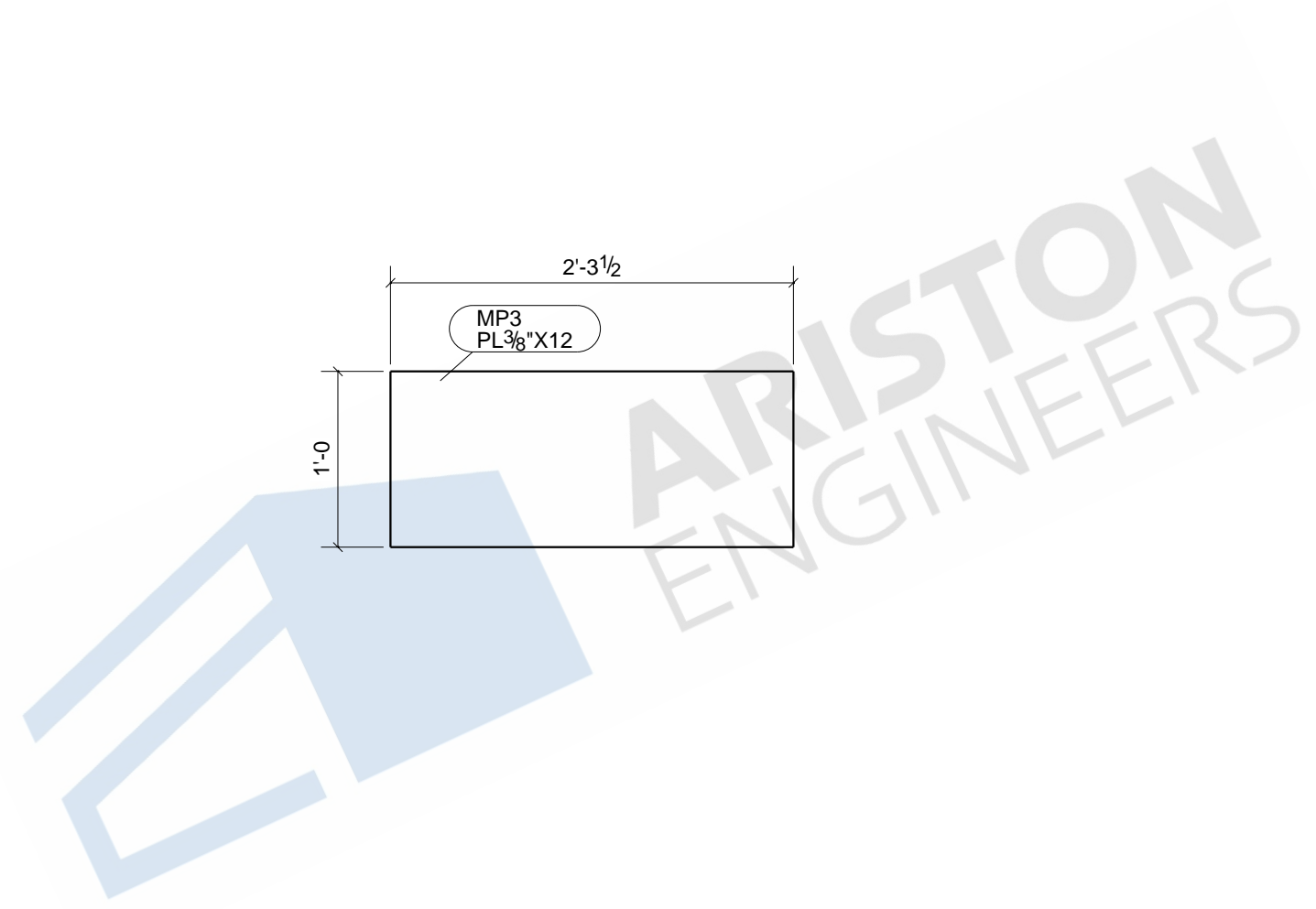
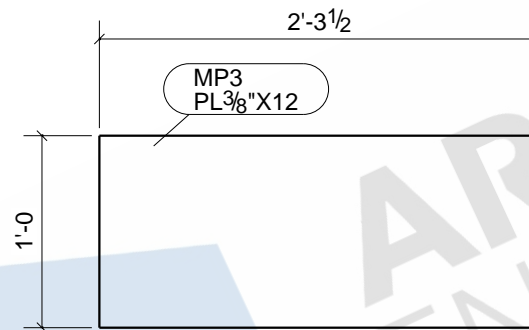

BOLT : 3/4" A325N UNO		MATERIAL	
HOLES : 13/16" UNO		W SHAPES = A992 TUBES = A500 (46 KSI) SHOP PREP PER SPECS	
WELD : E-70XX		FINISH : NO PAINT	
REVISIONS		ITEM	MP3 - LOOSE PLATE
NO	DESCRIPTION	DATE	JDA MADISON SELF STORAGE
		ARCH	
		CONTR	
DWN : ASM		DATE:	CHK'D: NSP
JOB#			DATE:
		DWG NO.	MP3

10 - LOOSE PLATES - MP3

LINE	GRADE	SCOPE	QTY	DESCRIPTION	LENGTH	MARK	REMARK
	-		1	POST		1P01	SHOP PRIME
	A500-GR.C		1	HSS12X4X3/8	14'-3 3/4"	1P01	
	A36		4	L3X3X5/16	0'-4"	a92	

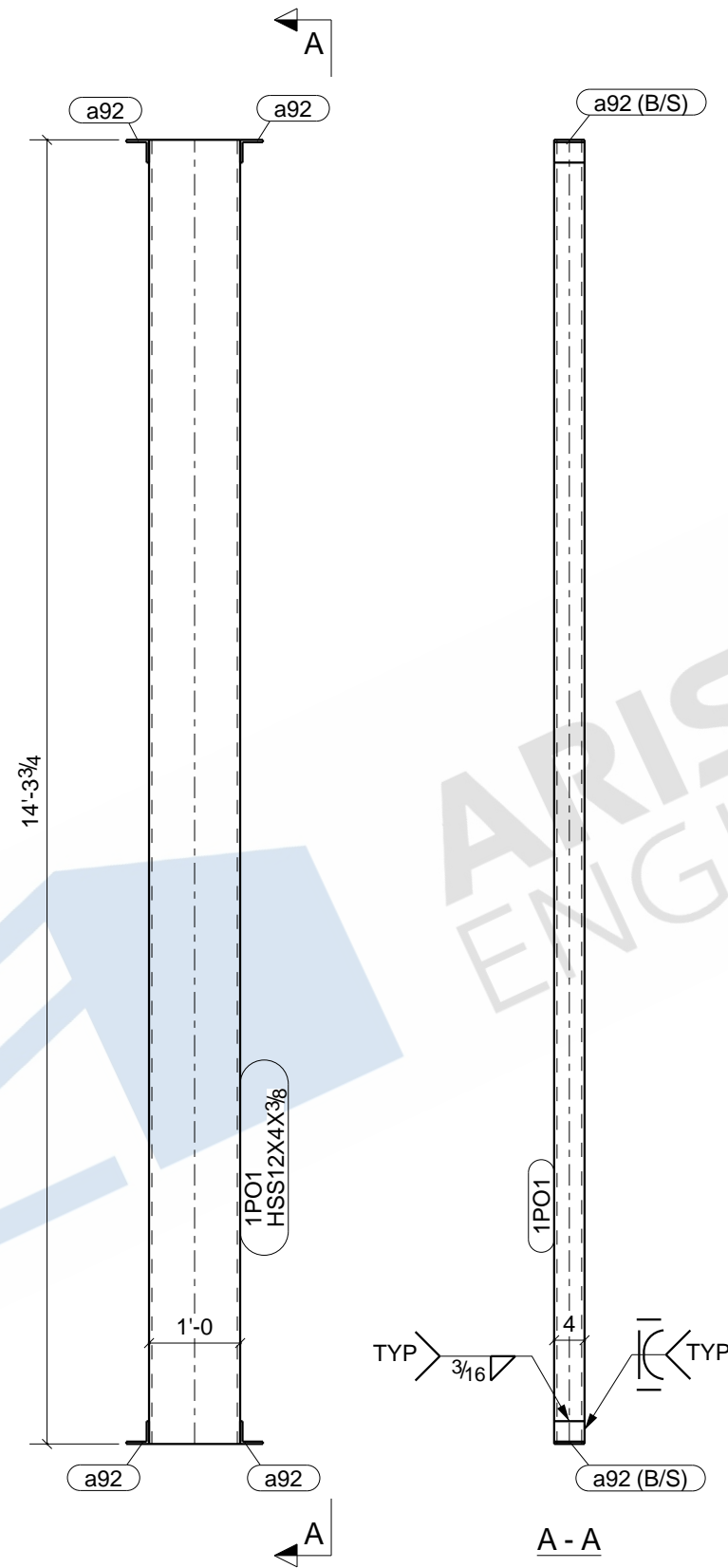

ONE - POST - 1P01

BOLT : 3/4" A325N UNO		MATERIAL	
HOLES : 13/16" UNO		W SHAPES = A992	
WELD : E-70XX		TUBES = A500 (46 KSI)	
FINISH : SHOP PRIME		SHOP PREP PER SPECS	
REVISIONS		ITEM	1P01 - POST
NO	DESCRIPTION	DATE	JDA MADISON SELF STORAGE
		ARCH	
		CONTR	
DWN : ASM	DATE:	CHK'D: NSP	DATE:
JOB#		DWG NO.	1P01

LINE	GRADE	SCOPE	QTY	DESCRIPTION	LENGTH	MARK	REMARK
	-		1	POST		1PO2	SHOP PRIME
	A500-GR.C		1	HSS12X4X3/8	9'-10"	1PO2	
	A36		4	L3X3X5/16	0'-4"	a92	

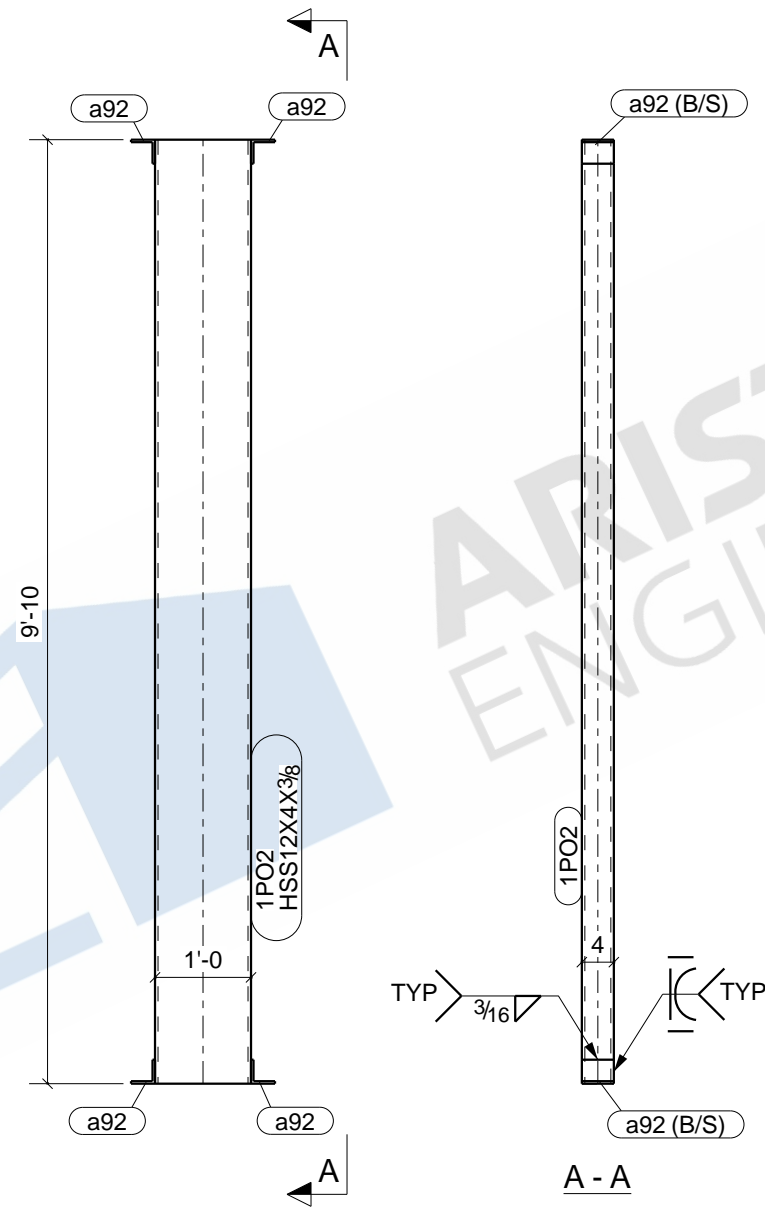

ONE - POST - 1PO2

BOLT : 3/4" A325N UNO		MATERIAL	
HOLES : 13/16" UNO		W SHAPES = A992	
WELD : E-70XX		TUBES = A500 (46 KSI)	
FINISH : SHOP PRIME		SHOP PREP PER SPECS	
REVISIONS		ITEM	1PO2 - POST
NO	DESCRIPTION	DATE	JDA MADISON SELF STORAGE
		ARCH	
		CONTR	
DWN : ASM	DATE:	CHK'D: NSP	DATE:
JOB#		DWG NO.	1PO2

LINE	GRADE	SCOPE	QTY	DESCRIPTION	LENGTH	MARK	REMARK
-	-	-	4	RAMP_RAILS		RR501	SHOP PRIME
A53			4	PIPE1-1/4SCH40	22'-9 15/16"	RR501	
A53			8	PIPE1-1/4SCH40	3'-0 3/16"	po501	
A53			16	PIPE1-1/4SCH40	3'-0 3/16"	po502	

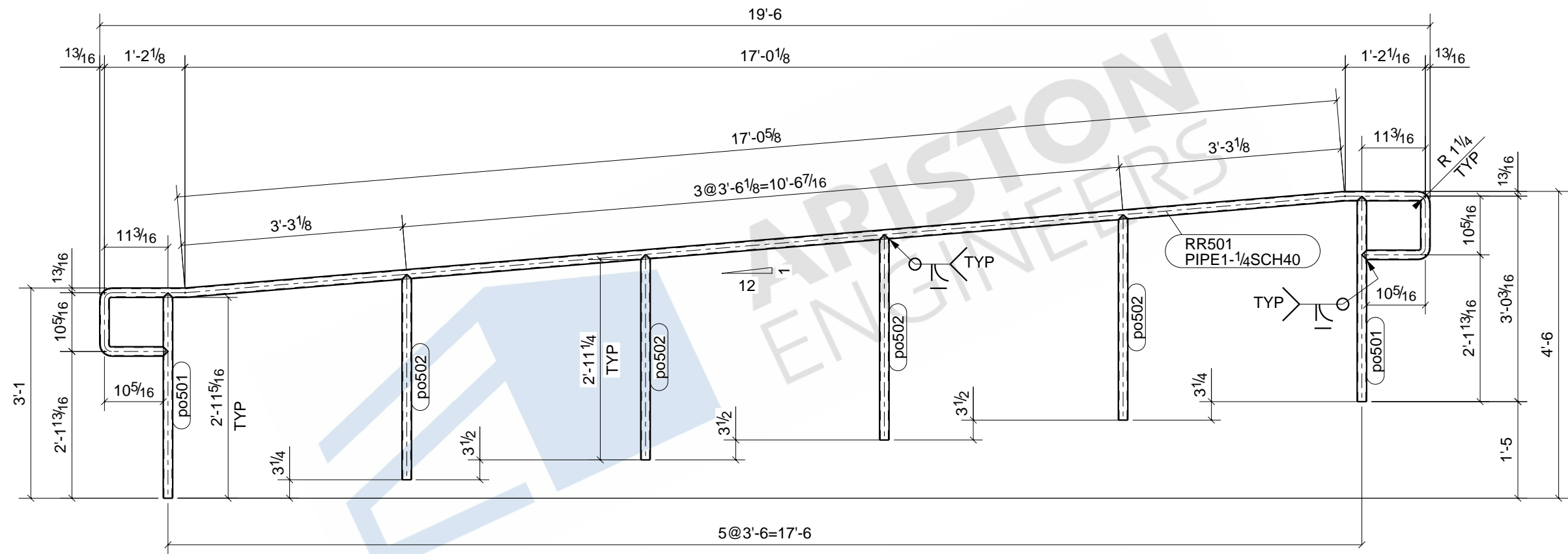

Tekla structures

4 - RAMP_RAILS - RR501

BOLT : 3/4" A325N UNO		MATERIAL	
HOLES : 13/16" UNO		W SHAPES = A992	
WELD : E-70XX		TUBES = A500 (46 KSI)	
FINISH : SHOP PRIME		SHOP PREP PER SPECS	
REVISIONS		ITEM	RR501 - RAMP RAIL
NO	DESCRIPTION	DATE	JDA MADISON SELF STORAGE
		ARCH	
		CONTR	
DWN : ASM		DATE:	CHK'D: NSP
JOB#			DATE:
		DWG NO.	RR501

LINE	GRADE	SCOPE	QTY	DESCRIPTION	LENGTH	MARK	REMARK
	-		19	SLEEVES		SL1	NO PAINT
	A53		19	PIPE1-1/4SCH40	0'-1 3/8"	SL1	

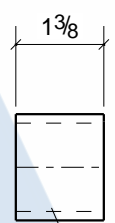
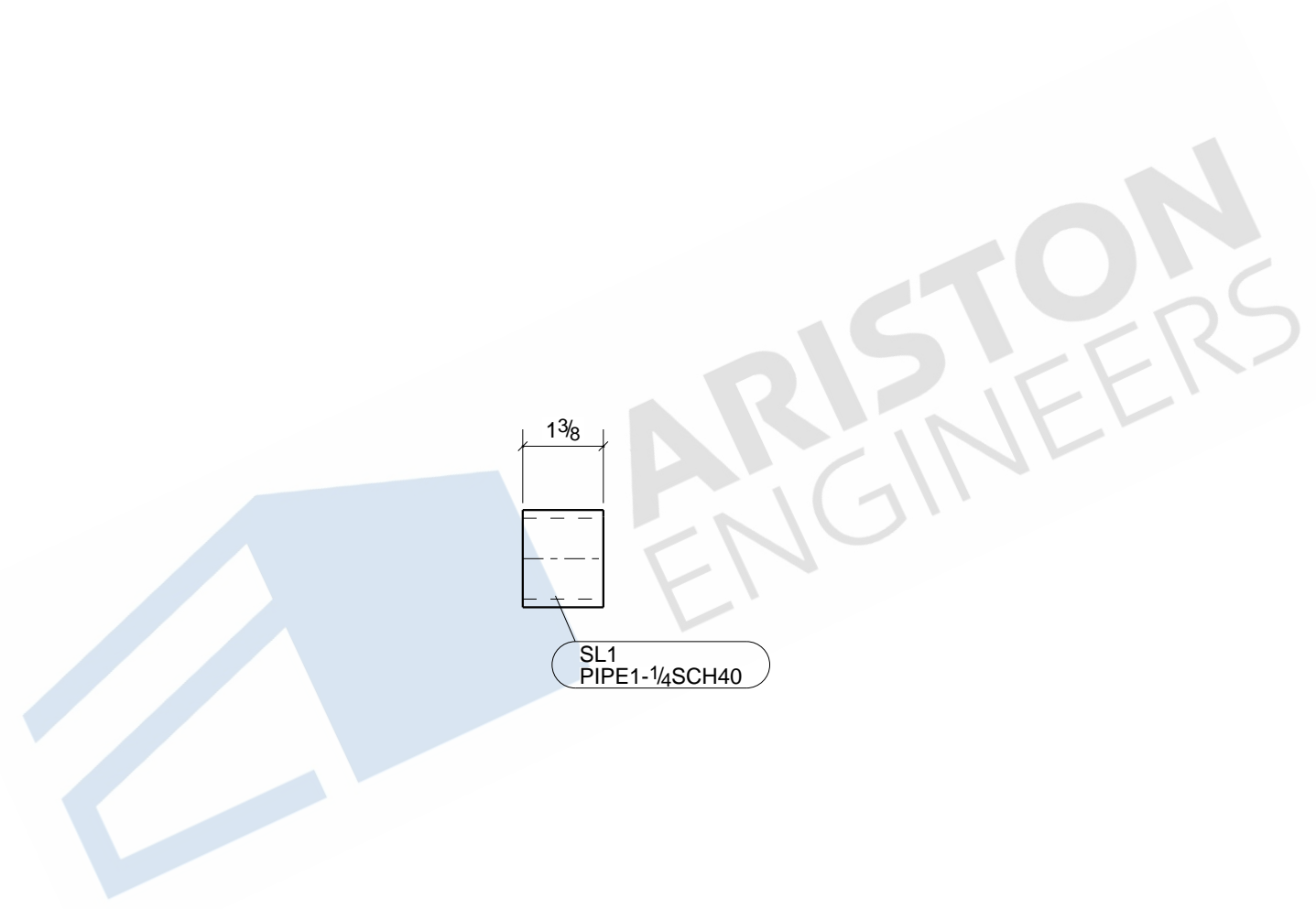

SL1
PIPE 1-1/4 SCH40

19 - SLEEVES - SL1

BOLT : 3/4" A325N UNO		MATERIAL	
HOLES : 13/16" UNO		W SHAPES = A992	
WELD : E-70XX		TUBES = A500 (46 KSI)	
FINISH : NO PAINT		SHOP PREP PER SPECS	
REVISIONS		ITEM	SL1 - SLEEVE
NO	DESCRIPTION	DATE	JDA MADISON SELF STORAGE
		ARCH	
		CONTR	
DWN : ASM		DATE:	CHK'D: MVK
JOB#			DATE:
		DWG NO.	SL1

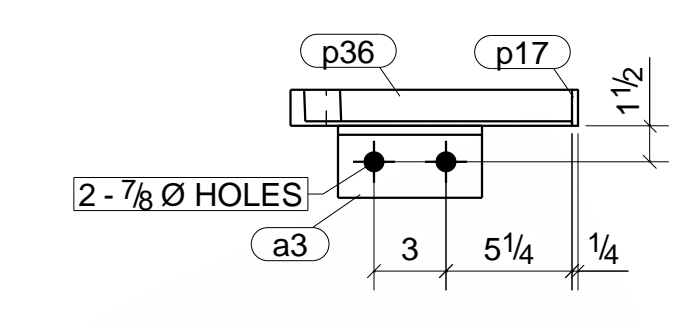
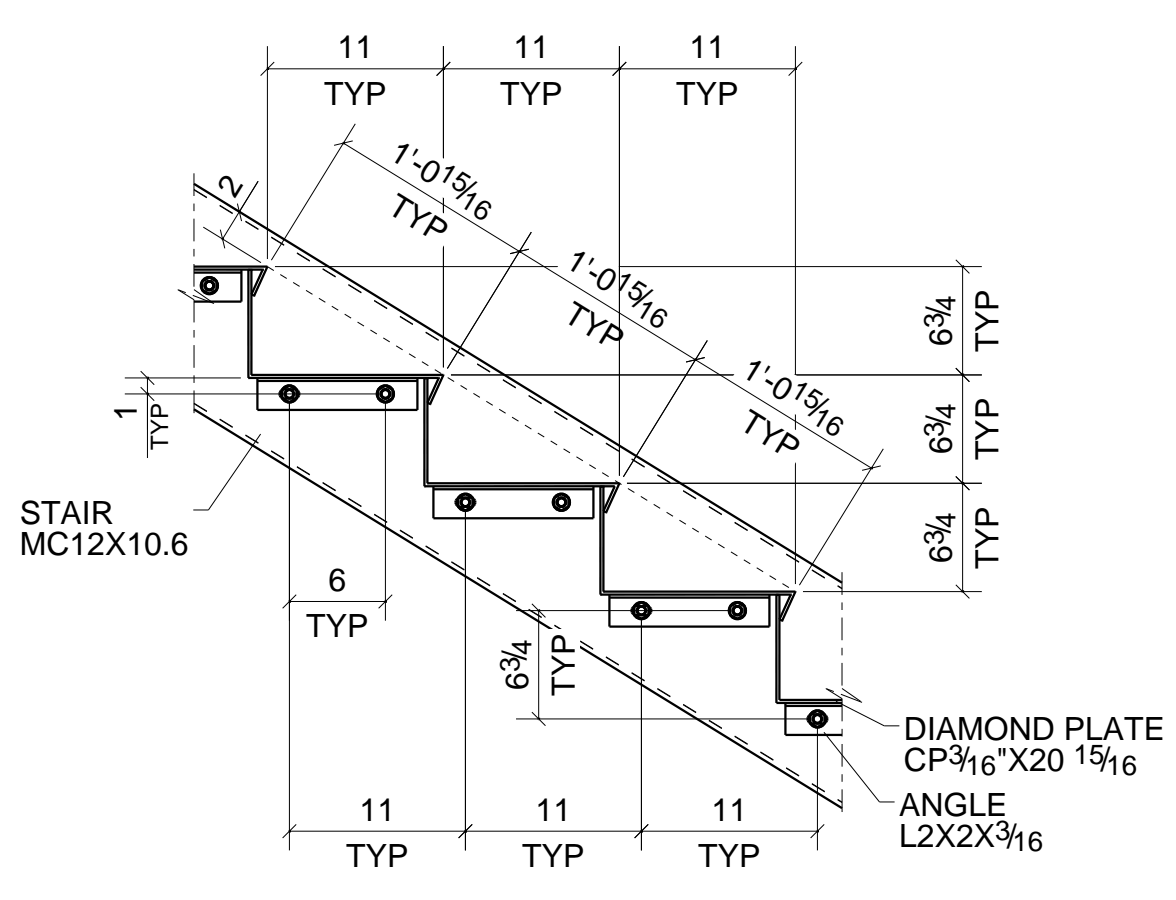
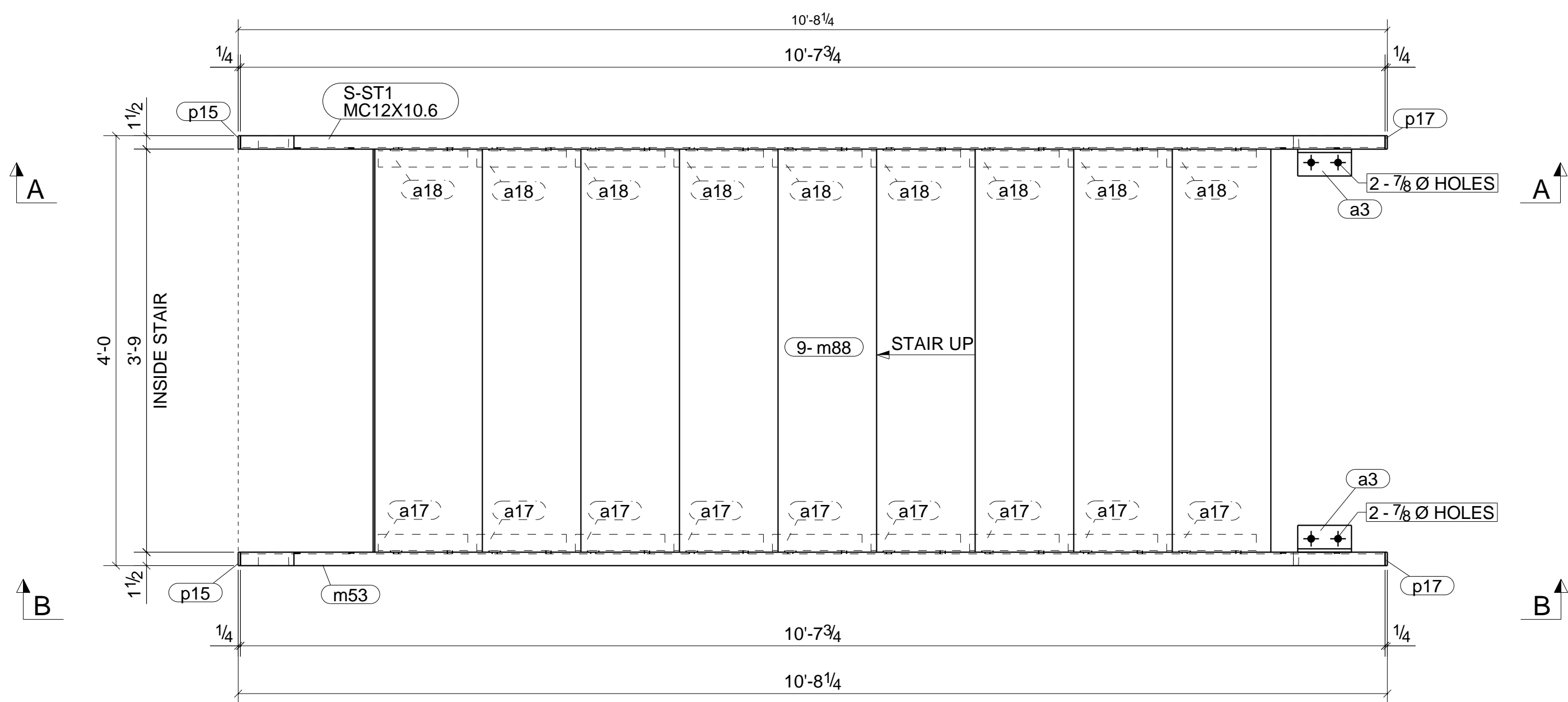

LINE	GRADE	SCOPE	QTY	DESCRIPTION	LENGTH	MARK	REMARK
-	-	-	1	STAIR		S-ST1	SHOP PRIME
A36			1	MC12X10.6	12'-8 3/16"	S-ST1	
A36			2	L3-1/2X3X3/8	0'-6"	a3	
A36			9	L2X2X3/16	0'-10"	a17	
A36			9	L2X2X3/16	0'-10"	a18	
A36			1	MC12X10.6	12'-8 3/16"	m53	
A36			9	CP3/16\"X20 15/16"	3'-9"	m88	
A36			2	PL1/4\"X1 1/2"	0'-6"	p14	
A36			2	PL1/4\"X1 1/2"	0'-2 3/16"	p15	
A36			2	PL1/4\"X1 1/2"	0'-8 1/16"	p17	
A36			2	PL1/4\"X1 1/2"	0'-10 1/4"	p36	
-			36	1/2\"Ø A325N BOLT	0'-1 1/4"		
-			4	3/4\"Ø TITEN_HD BOLT	0'-5"		FIELD BOLT

DETAIL-A

C - C

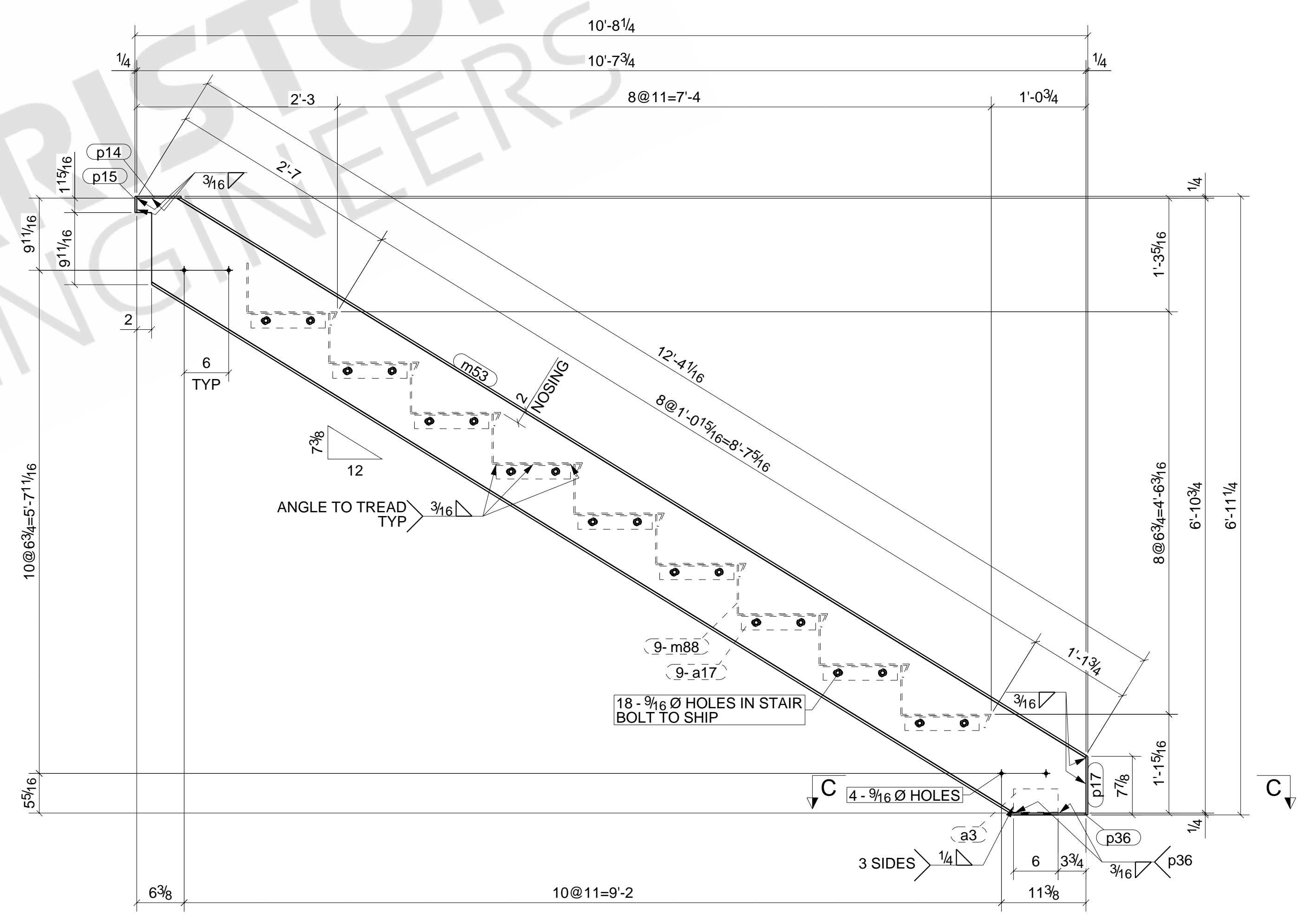
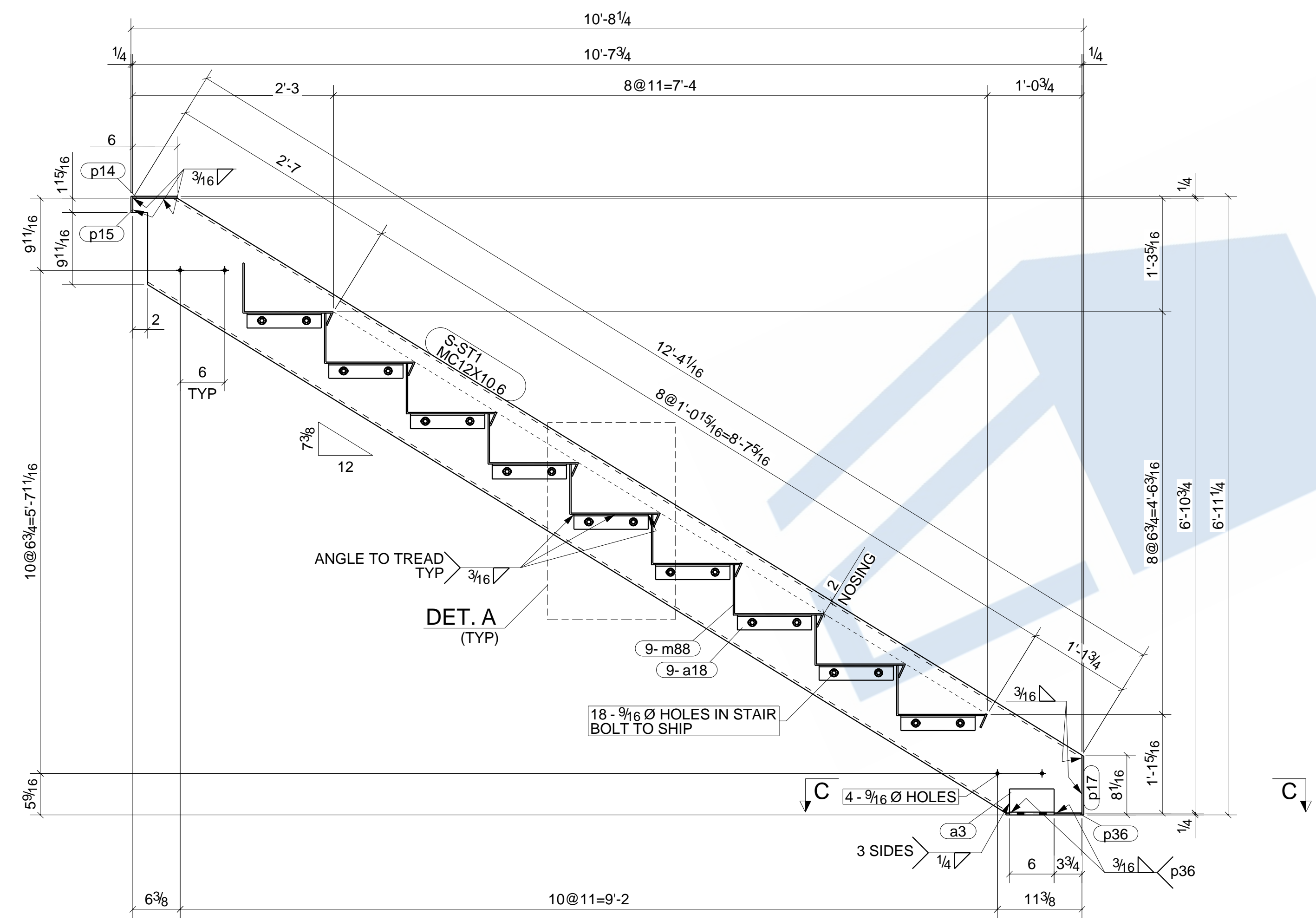

A - A

B - B

ONE - STAIR - S-ST1

BOLT : 3/4" A325N UNO		MATERIAL	
HOLES : 13/16" UNO		W SHAPES = A992	
WELD : E-70XX		TUBES = A500 (46 KSI)	
FINISH : SHOP PRIME		SHOP PREP PER SPECS	
REVISIONS		ITEM	S-ST1 - STAIR
NO	DESCRIPTION	JOB	JDA MADISON SELF STORAGE
		ARCH	
		CONTR	
		DWN : ASM	DATE:
		CHK'D: NSP	DATE:
		JOB#	DWG NO.
			S-ST1

LINE	GRADE	SCOPE	QTY	DESCRIPTION	LENGTH	MARK	REMARK
-	-	-	1	STAIR		S-ST2	SHOP PRIME
A36			1	MC12X10.6	13'-0 15/16"	S-ST2	
A36			10	L2X2X3/16	0'-10"	a17	
A36			10	L2X2X3/16	0'-10"	a18	
A36			1	MC12X10.6	13'-0 15/16"	m51	
A36			10	CP3/16"X20 15/16"	3'-9"	m88	
A36			2	PL1/4"X1 1/2"	0'-6"	p14	
A36			2	PL1/4"X1 1/2"	0'-2 3/16"	p15	
A36			2	PL1/4"X1 1/2"	0'-6 1/4"	p16	
-			40	1/2"Ø A325N BOLT	0'-1 1/4"		

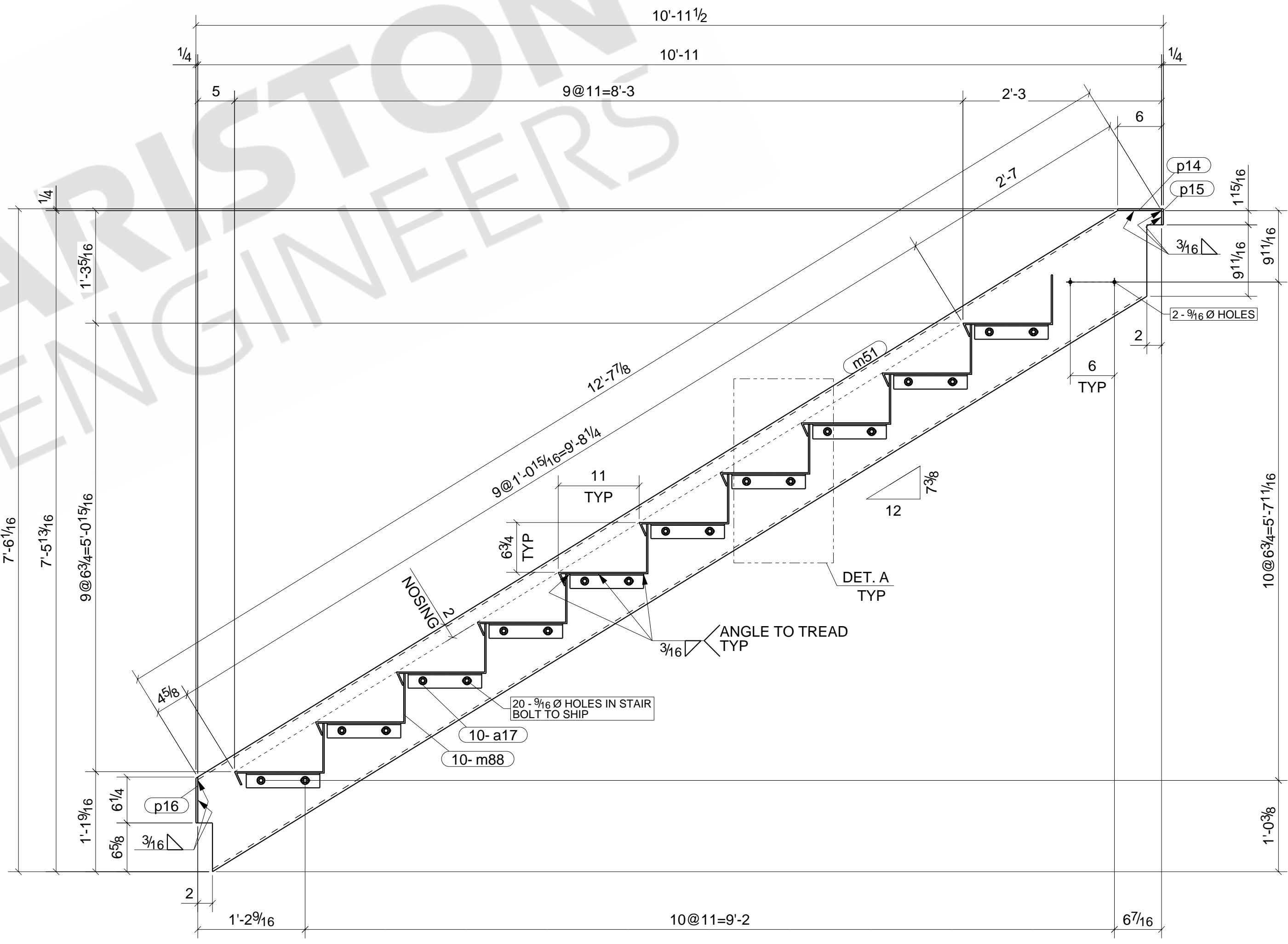
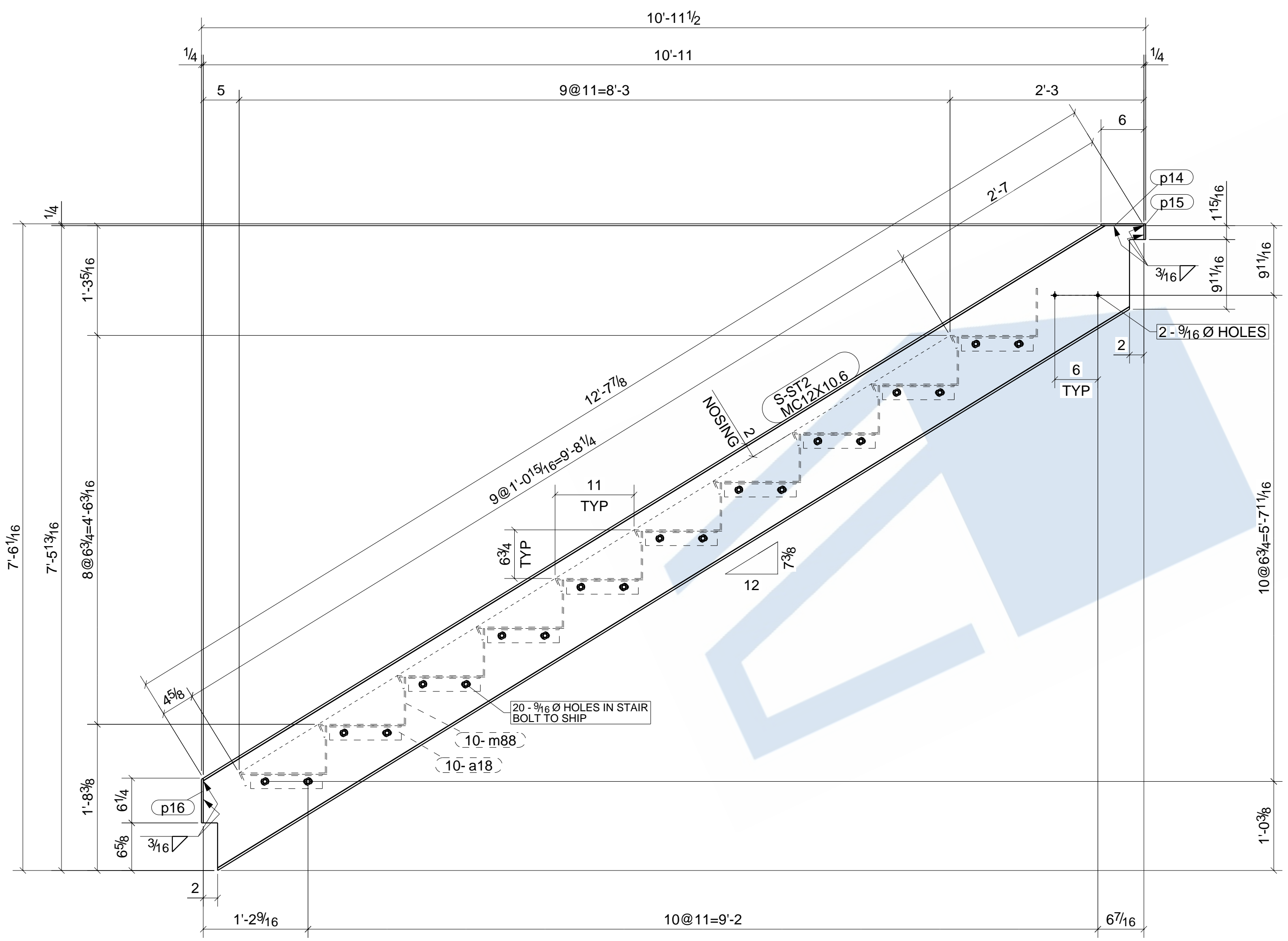
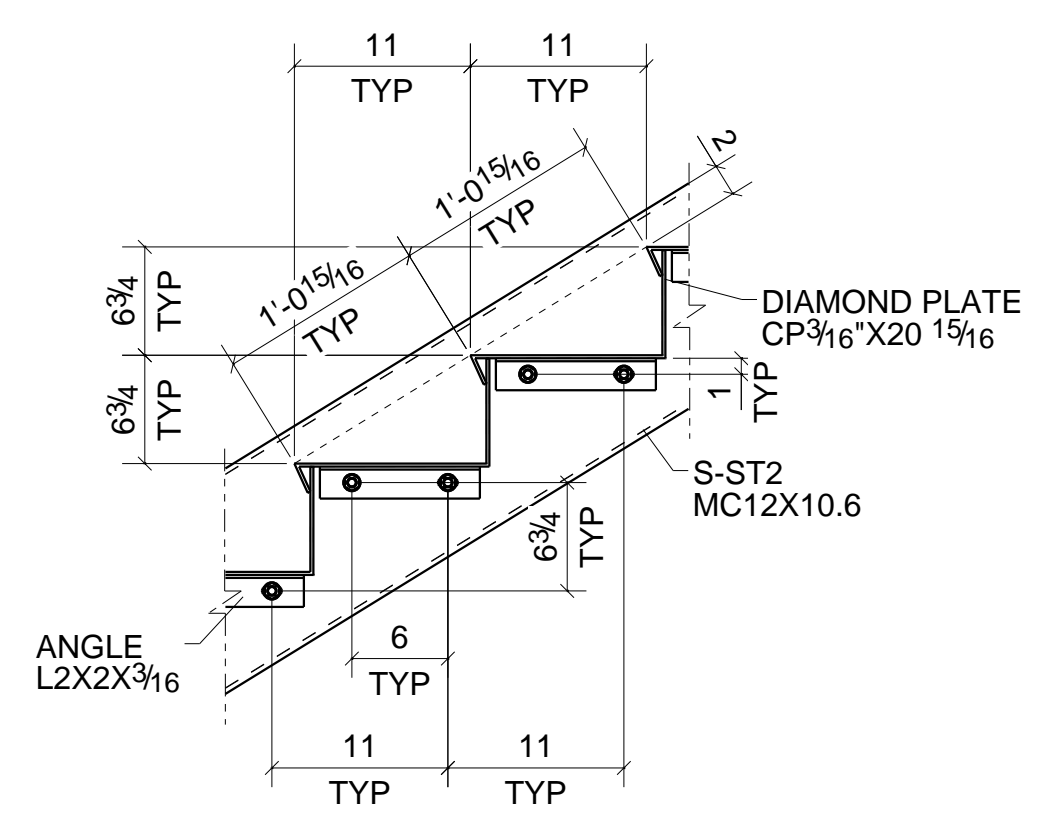
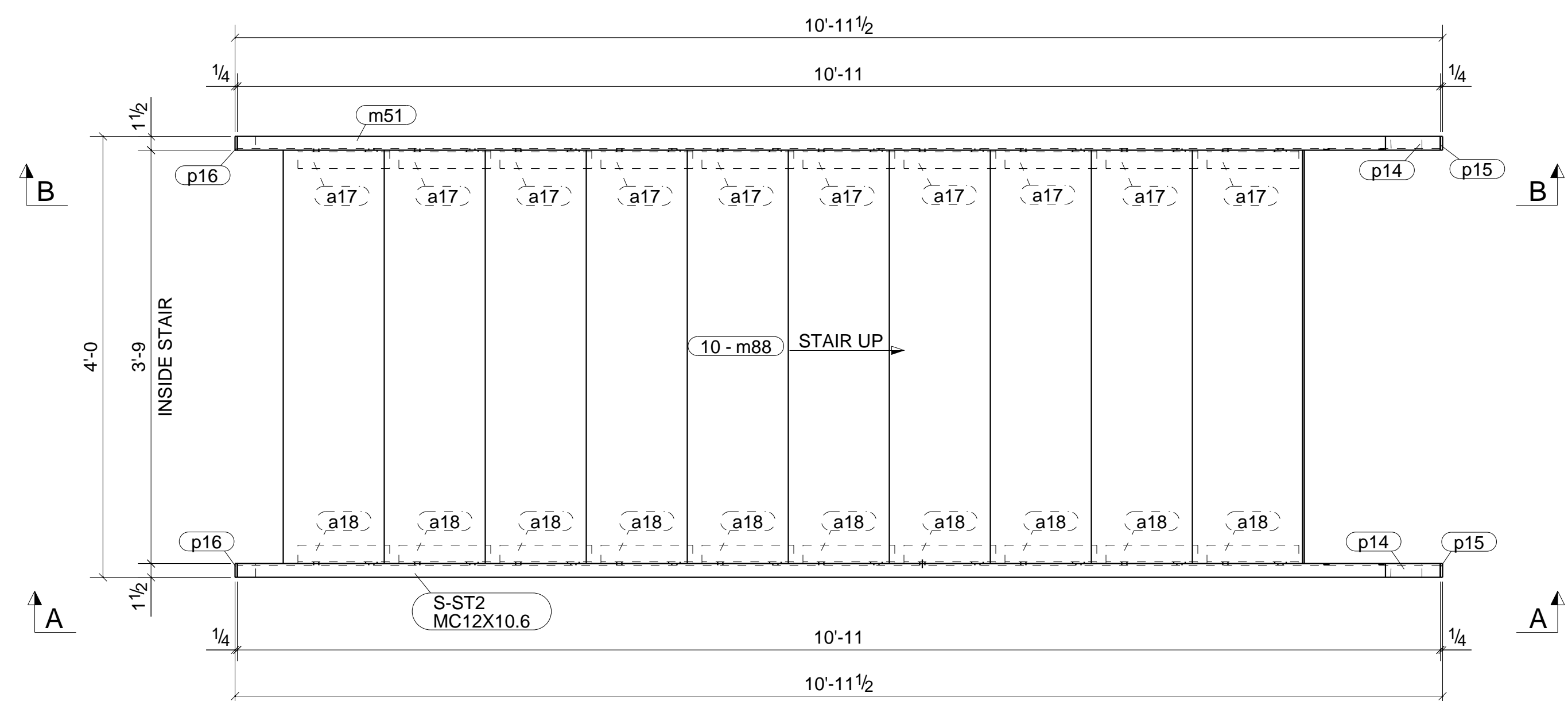

A - A

B - B

ONE - STAIR - S-ST2

BOLT : 3/4" A325N UNO		MATERIAL	
HOLES : 13/16" UNO		W SHAPES = A992	
WELD : E-70XX		TUBES = A500 (46 KSI)	
FINISH : SHOP PRIME		SHOP PREP PER SPECS	
REVISIONS		ITEM	S-ST2 - STAIR
NO	DESCRIPTION	DATE	JDA MADISON SELF STORAGE
		ARCH	
		CONTR	
		DWN : ASM	DATE:
		CHK'D: NSP	DATE:
		JOB#	DWG NO.
			S-ST2

LINE	GRADE	SCOPE	QTY	DESCRIPTION	LENGTH	MARK	REMARK
	-		1	TRACK		2M1	NO PAINT
	A36		1	C6X8.2	15'-1"	2M1	

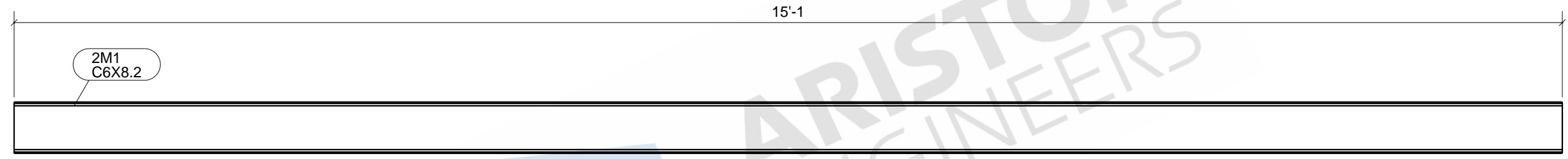

2M1
C6X8.2

15'-1

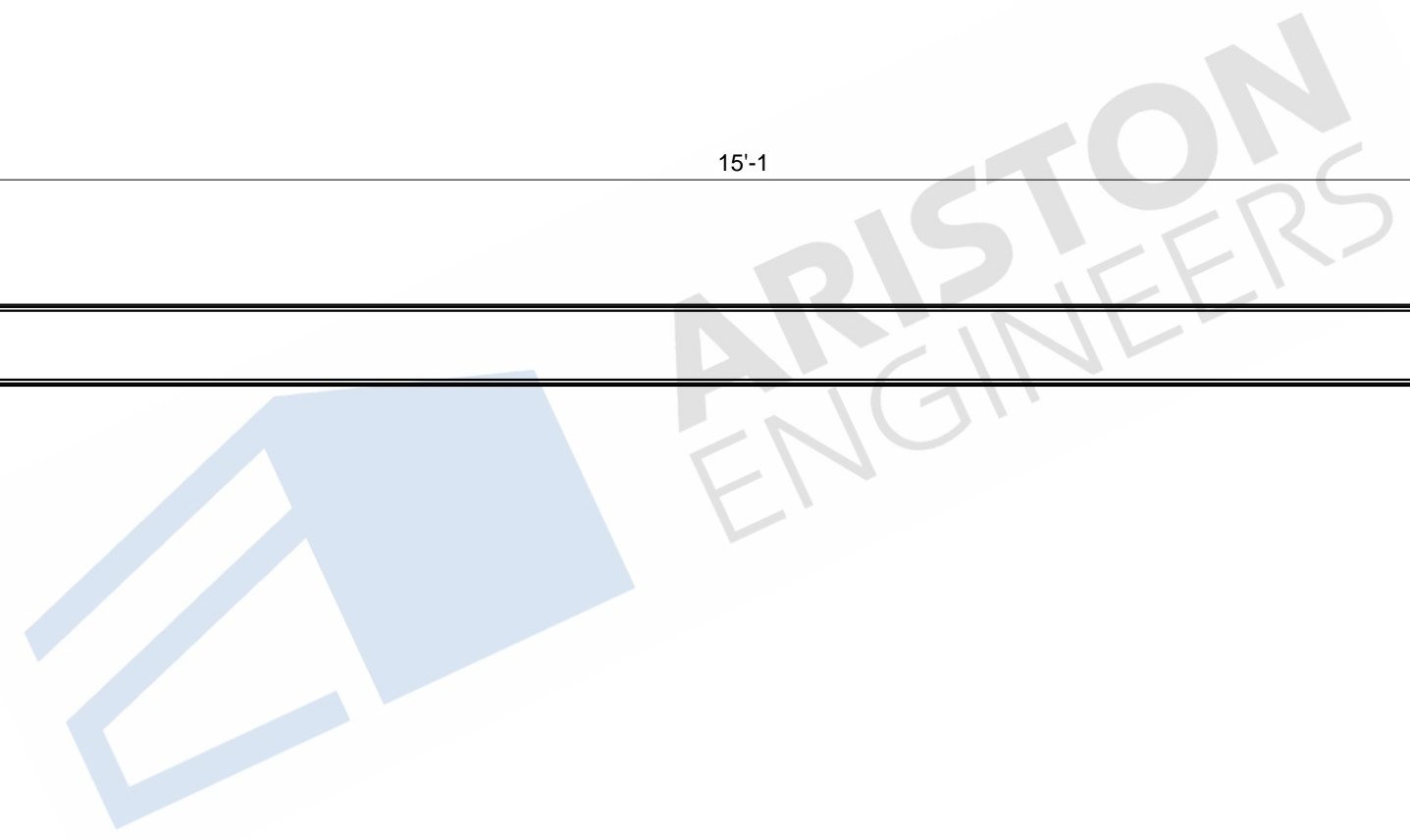

ONE - TRACK - 2M1

BOLT : 3/4" A325N UNO		MATERIAL	
HOLES : 13/16" UNO		W SHAPES = A992 TUBES = A500 (46 KSI) SHOP PREP PER SPECS	
WELD : E-70XX		FINISH : NO PAINT	
REVISIONS		ITEM	2M1 - TRACK
NO	DESCRIPTION	DATE	JDA MADISON SELF STORAGE
		ARCH	
		CONTR	
DWN : ASM		DATE:	CHK'D: NSP
JOB#			DATE:
		DWG NO.	2M1

Tekla structures

LINE	GRADE	SCOPE	QTY	DESCRIPTION	LENGTH	MARK	REMARK
	-		1	TREAD		S-TR1	SHOP PRIME
	A36		1	CP3/16"X12 1/16"	3'-9"	S-TR1	

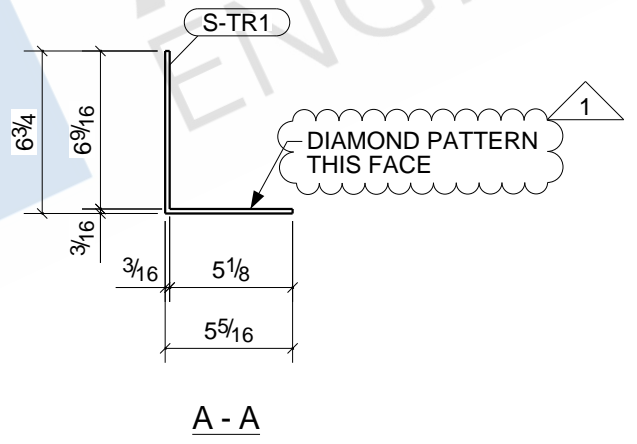
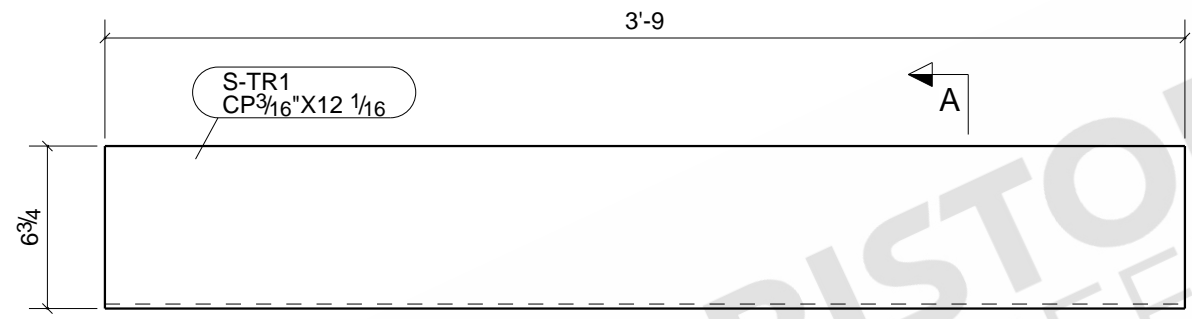

ONE - TREAD - S-TR1

BOLT : 3/4" A325N UNO		MATERIAL	
HOLES : 13/16" UNO		W SHAPES = A992	
WELD : E-70XX		TUBES = A500 (46 KSI)	
FINISH : SHOP PRIME		SHOP PREP PER SPECS	
REVISIONS		ITEM	S-TR1 - TREAD
NO	DESCRIPTION	DATE	JDA MADISON SELF STORAGE
		ARCH	
		CONTR	
DWN : MVK	DATE:	CHK'D: NSP	DATE:
JOB#		DWG NO.	S-TR1

LINE	GRADE	SCOPE	QTY	DESCRIPTION	LENGTH	MARK	REMARK
	-		2	TREADS		S-TR2	SHOP PRIME
	A36		2	CP3/16"X12 3/16"	3'-9"	S-TR2	

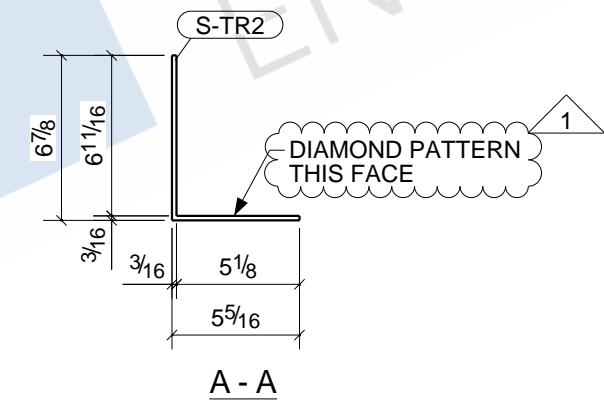
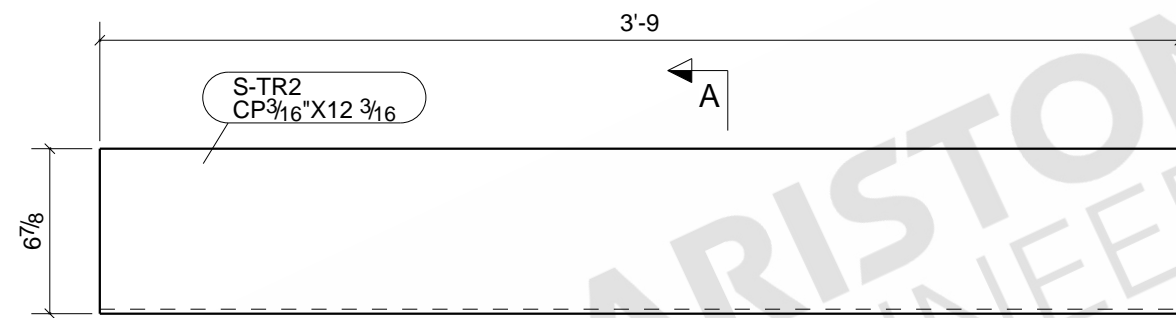

2 - TREADS - S-TR2

BOLT : 3/4" A325N UNO		MATERIAL	
HOLES : 13/16" UNO		W SHAPES = A992 TUBES = A500 (46 KSI) SHOP PREP PER SPECS	
WELD : E-70XX		FINISH : SHOP PRIME	
REVISIONS		ITEM	S-TR2 - TREAD
NO	DESCRIPTION	DATE	JDA MADISON SELF STORAGE
		ARCH	
		CONTR	
		DWN : MVK	DATE:
		CHK'D: NSP	DATE:
		JOB#	DWG NO. S-TR2

Tekla structures

LINE	GRADE	SCOPE	QTY	DESCRIPTION	LENGTH	MARK	REMARK
	-		1	WALLRAIL		S-WR1	SHOP PRIME
	A53		1	PIPE 1-1/4 SCH40	9'-8 15/16"	S-WR1	
	A36		3	WALLRAIL BRACKET BOI		br3	
	A36		2	PL 1/8" X 1 5/8"	0'-1 5/8"	p24	

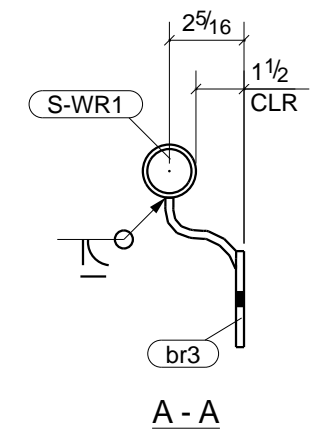
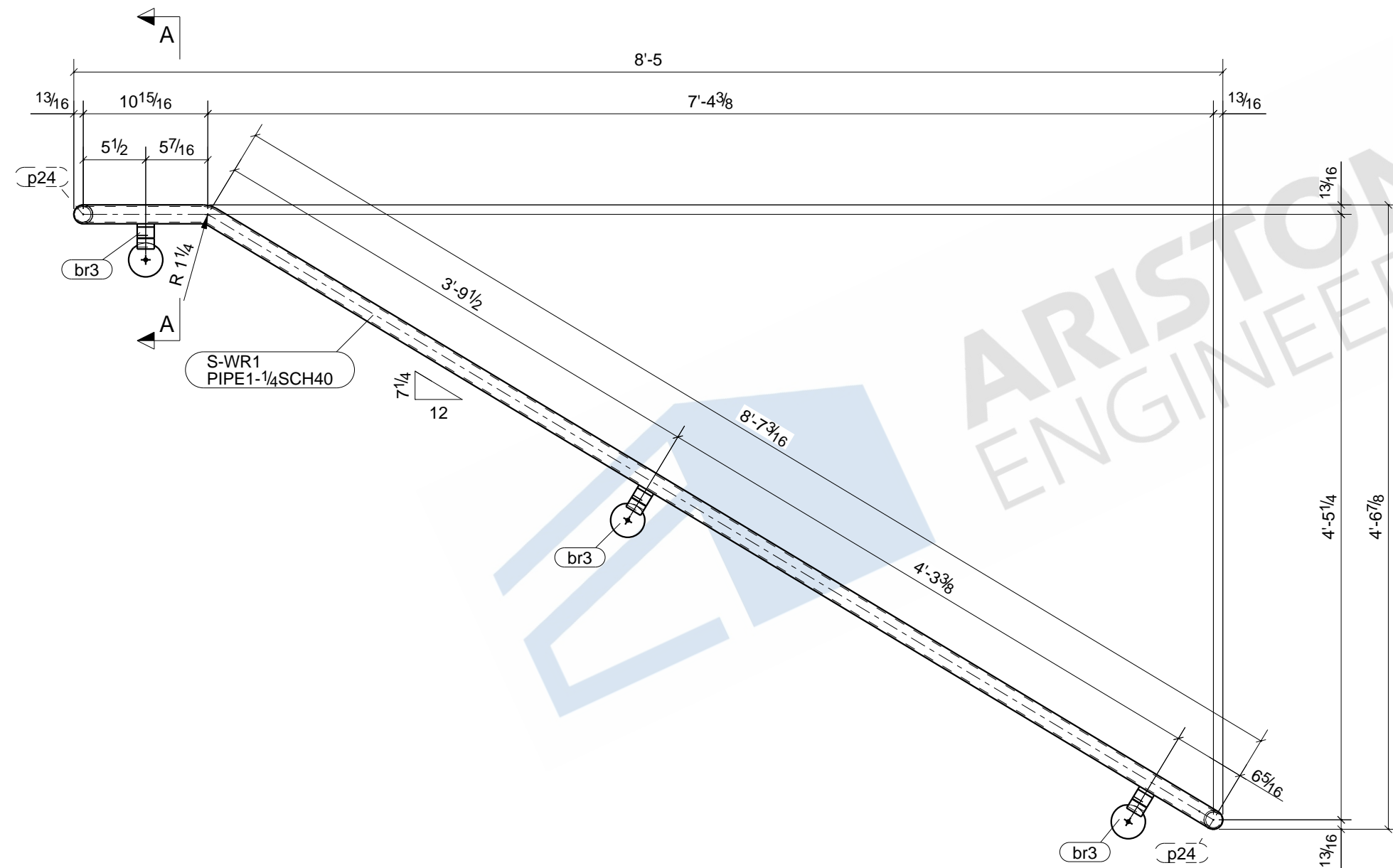
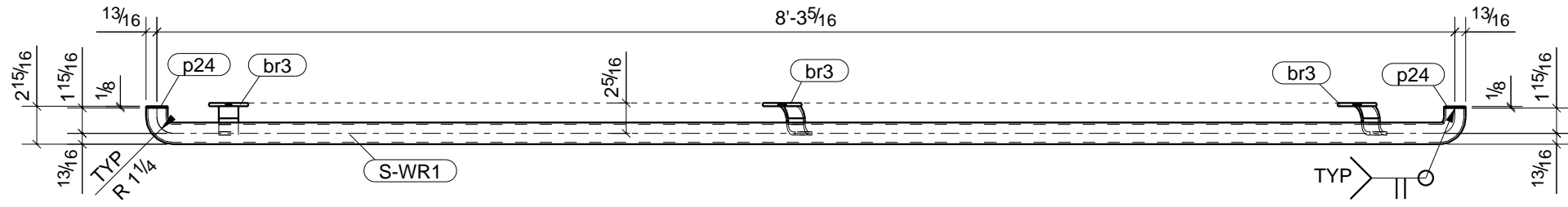

BOLT : 3/4" A325N UNO		MATERIAL	
HOLES : 13/16" UNO		W SHAPES = A992	
WELD : E-70XX		TUBES = A500 (46 KSI)	
FINISH : SHOP PRIME		SHOP PREP PER SPECS	
REVISIONS		ITEM	S-WR1 - WALLRAIL
NO	DESCRIPTION	DATE	JOB
			JDA MADISON SELF STORAGE
			ARCH
			CONTR
	DWN : ASM	DATE:	CHK'D: NSP
	JOB#		DATE:
		DWG NO.	S-WR1

ONE - WALLRAIL - S-WR1

LINE	GRADE	SCOPE	QTY	DESCRIPTION	LENGTH	MARK	REMARK
	-		2	WALLRAILS		S-WR2	SHOP PRIME
	A53		2	PIPE 1-1/4 SCH40	14'-1 1/4"	S-WR2	
	A36		8	WALLRAIL BRACKET BOI		br3	
	A36		4	PL 1/8" X 1 5/8"	0'-1 5/8"	p24	

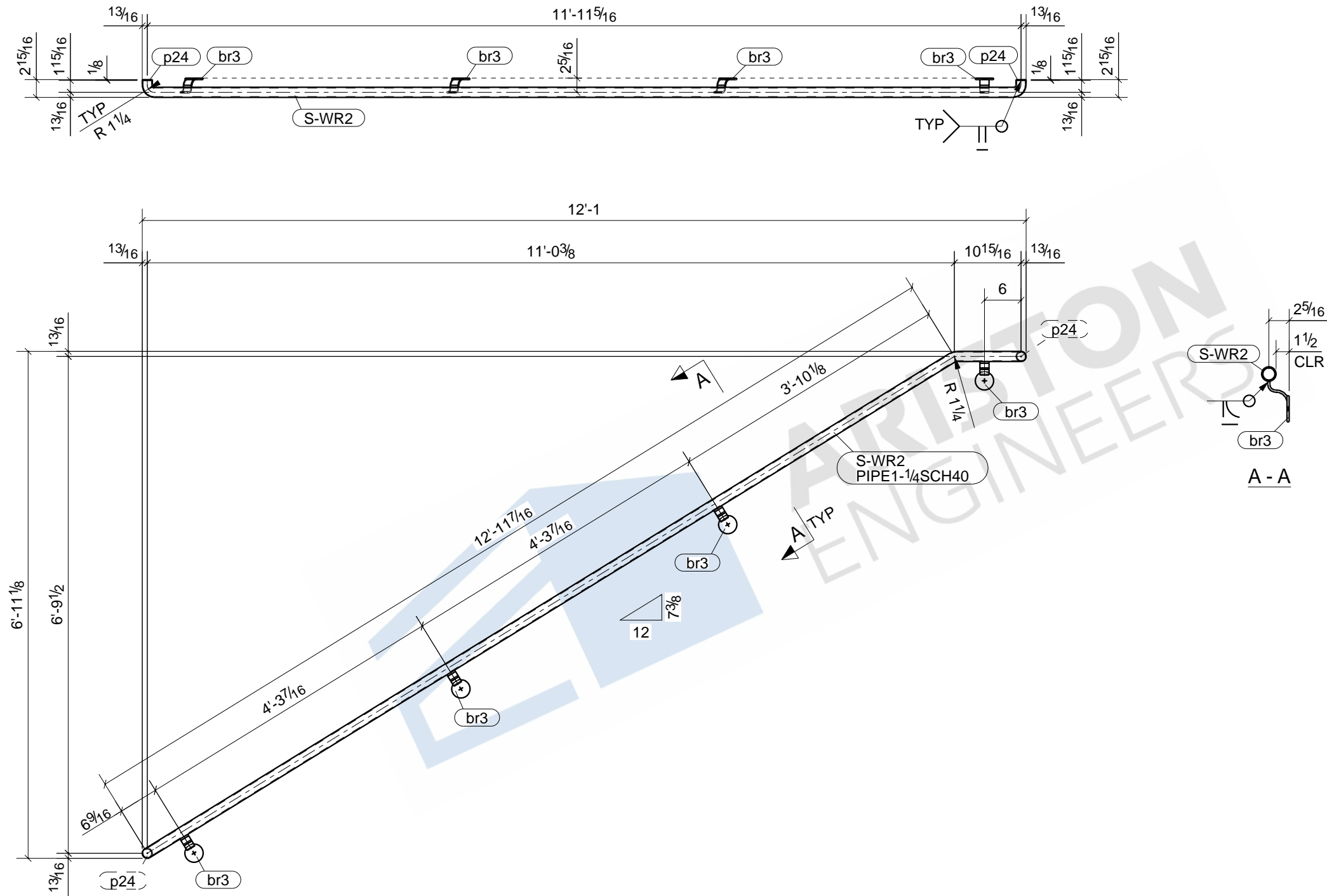

2 - WALLRAILS - S-WR2

Tekla structures

BOLT : 3/4" A325N UNO		MATERIAL	
HOLES : 13/16" UNO		W SHAPES = A992	
WELD : E-70XX		TUBES = A500 (46 KSI)	
FINISH : SHOP PRIME		SHOP PREP PER SPECS	
REVISIONS		ITEM	S-WR2 - WALLRAIL
NO	DESCRIPTION	DATE	JDA MADISON SELF STORAGE
		ARCH	
		CONTR	
DWN : ASM		DATE:	CHK'D: NSP
JOB#			DATE:
		DWG NO.	S-WR2