

BILL OF MATERIAL					
MARK	QTY	DESCRIPTION	LENGTH	WEIGHT	REMARKS
B4	2	BEAMS			SQ-2
B4	2	HSS16X4X3/8	17'-8"	1587	SHOP PRIME A500-GR.B
a3	2	L3X3X1/4	5'-11"	58	A36
a4	2	L3X3X1/4	4'-11"	48	A36
a5	2	L3X3X1/4	5'-11"	58	A36
TOTAL WEIGHT THIS DRAWING				1751	

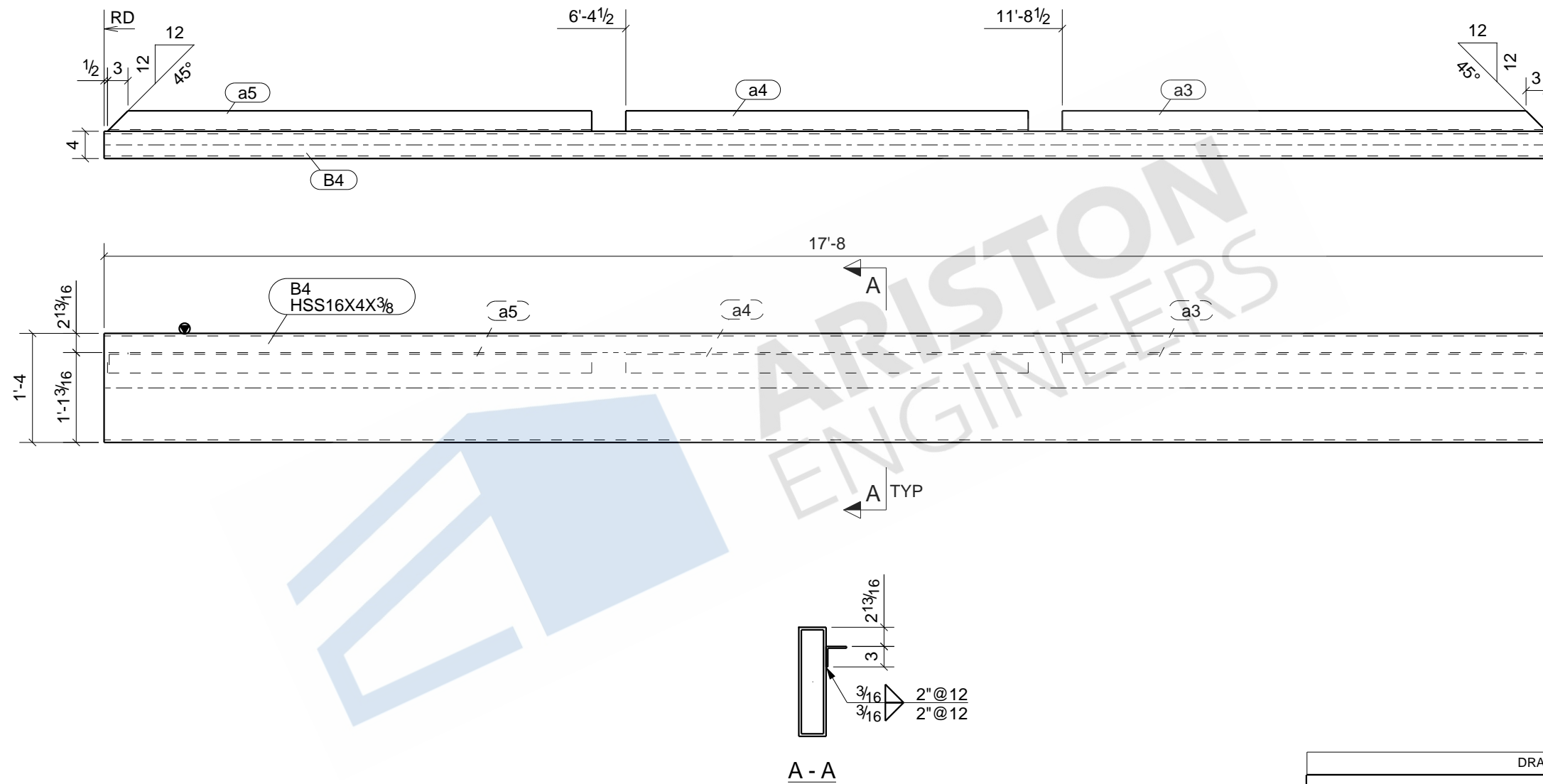

2 - BEAMS - B4

DRAWING STATUS			
SHOP PAINT:	2.5 MILS DFT	13/16" Ø HOLES(U.N.O.)	ALL STEEL TO ASTM A36 U.N.O.
SHOP PRIME		3/4" BOLTS, ST (U.N.O.)	ALL WELD TO BE E70 LH (U.N.O.)
PROJECT: TRULIANT MONUMENTAL STAIR			DRAWN BY: DSA
DESCRIPTION: BEAM			CHECKED BY: RAD
ARCH:	ENG:	JOB NO:	
CUSTOMER:			SHEET NO: B4

BILL OF MATERIAL					
MARK	QTY	DESCRIPTION	LENGTH	WEIGHT	REMARKS
B3	2	BEAMS			SO-2
B3	2	HSS16X4X3/8	5'-0"	449	SHOP PRIME A500-GR.B
TOTAL WEIGHT THIS DRAWING				449	

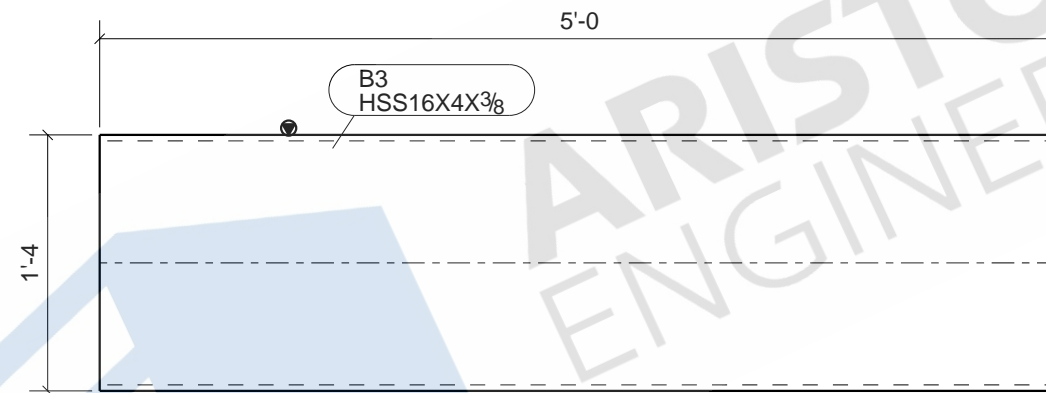

2 - BEAMS - B3

DRAWING STATUS			
SHOP PAINT:	2.5 MILS DFT	13/16" Ø HOLES(U.N.O.)	ALL STEEL TO ASTM A36 U.N.O.
SHOP PRIME		3/4" BOLTS, ST (U.N.O.)	ALL WELD TO BE E70 LH (U.N.O.)
PROJECT: TRULIANT MONUMENTAL STAIR			DRAWN BY: DSA
DESCRIPTION: BEAM			CHECKED BY: RAD
ARCH:		ENG:	JOB NO:
CUSTOMER:			SHEET NO: B3

BILL OF MATERIAL					
MARK	QTY	DESCRIPTION	LENGTH	WEIGHT	REMARKS
B2	2	BEAMS			SO-2
B2	2	HSS12X4X3/8	17'-8"	1251	SHOP PRIME A500-GR.B
TOTAL WEIGHT THIS DRAWING				1251	

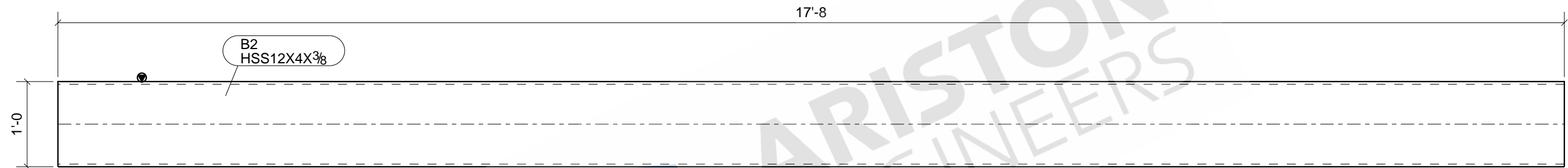

2 - BEAMS - B2

DRAWING STATUS			
SHOP PAINT:	2.5 MILS DFT	13/16" Ø HOLES(U.N.O.)	ALL STEEL TO ASTM A36 U.N.O.
SHOP PRIME		3/4" BOLTS, ST (U.N.O.)	ALL WELD TO BE E70 LH (U.N.O.)
PROJECT: TRULIANT MONUMENTAL STAIR			DRAWN BY: DSA
DESCRIPTION: BEAM			CHECKED BY: RAD
ARCH:		ENG:	JOB NO:
CUSTOMER:			SHEET NO: B2

BILL OF MATERIAL					
MARK	QTY	DESCRIPTION	LENGTH	WEIGHT	REMARKS
B1	4	BEAMS			SO-2
B1	4	HSS12X4X3/8	5'-8"	802	SHOP PRIME A500-GR.B
TOTAL WEIGHT THIS DRAWING				802	

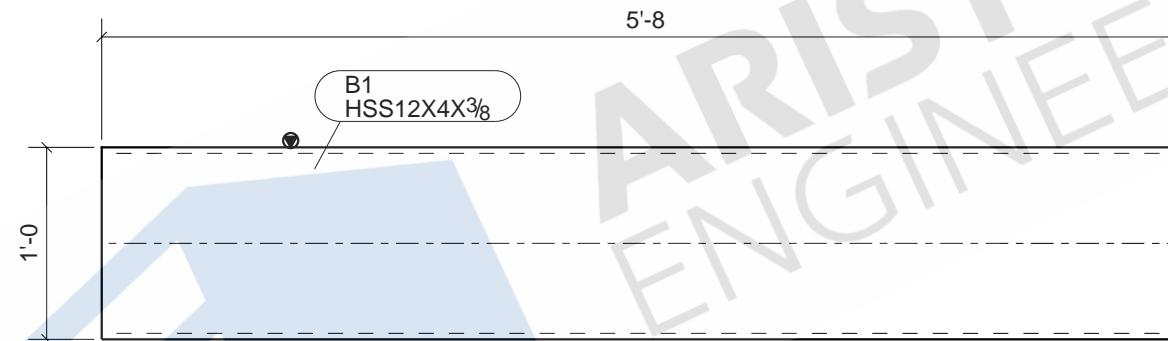

4 - BEAMS - B1

DRAWING STATUS			
SHOP PAINT:	2.5 MILS DFT	13/16" Ø HOLES(U.N.O.)	ALL STEEL TO ASTM A36 U.N.O.
SHOP PRIME		3/4" BOLTS, ST (U.N.O.)	ALL WELD TO BE E70 LH (U.N.O.)
PROJECT: TRULIANT MONUMENTAL STAIR			DRAWN BY: DSA
DESCRIPTION: BEAM			CHECKED BY: RAD
ARCH:		ENG:	JOB NO:
CUSTOMER:			SHEET NO: B1

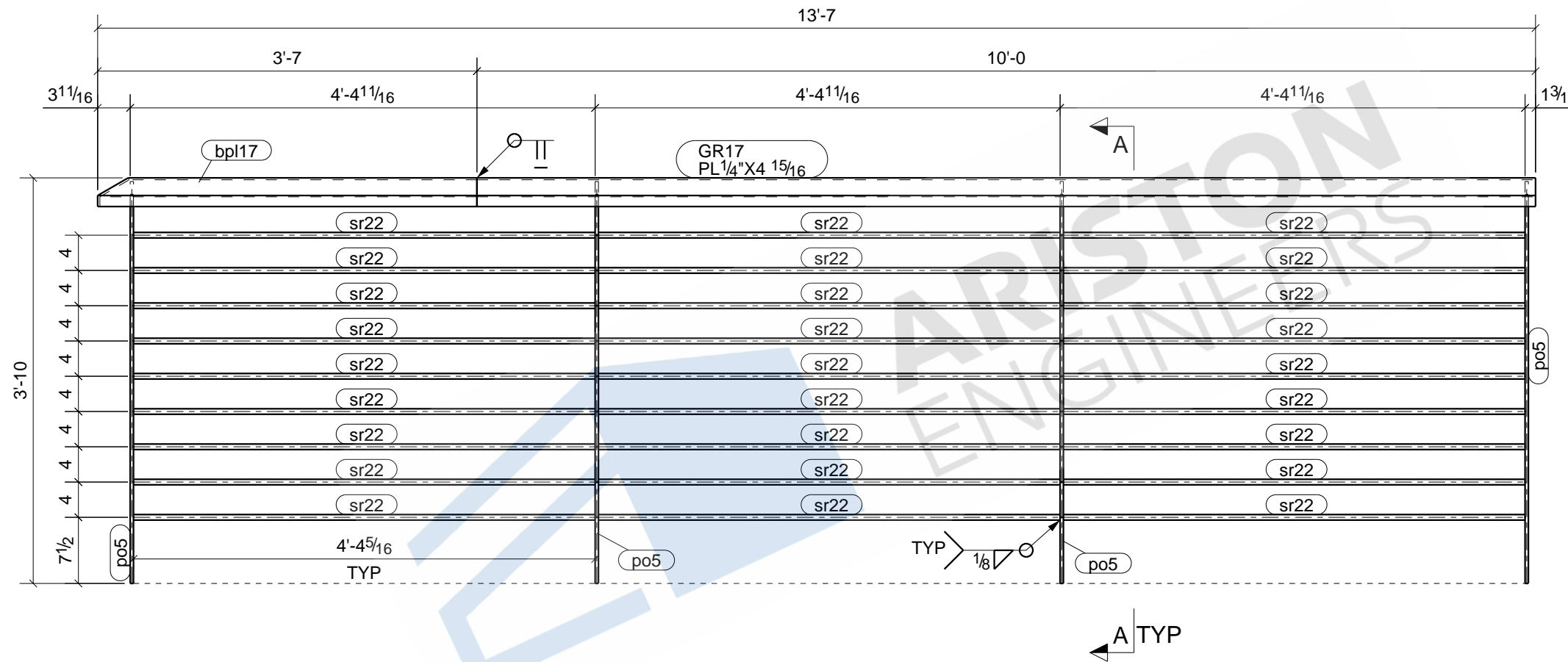
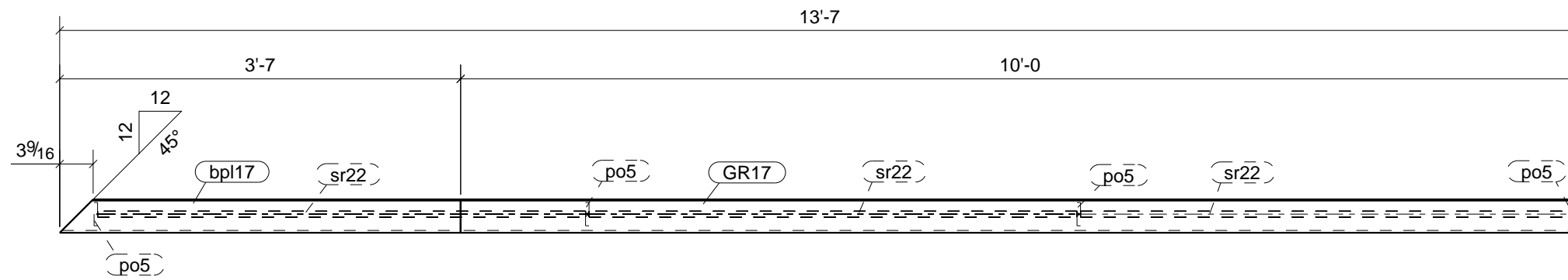

BILL OF MATERIAL					
MARK	QTY	DESCRIPTION	LENGTH	WEIGHT	REMARKS
GR17	1	GUARDRAIL			BEV-2
GR17	1	PL 1/4" X 4 15/16"	10'-0"	43	SHOP PRIME A36
sp17	1	PL 1/4" X 4 15/16"	3'-7"	15	A36
po5	4	PL 3/8" X 2 1/2"	3'-9 9/16"	48	A36
sr22	27	ROD 5/8"	4'-4 5/16"	111	A36
TOTAL WEIGHT THIS DRAWING				217	

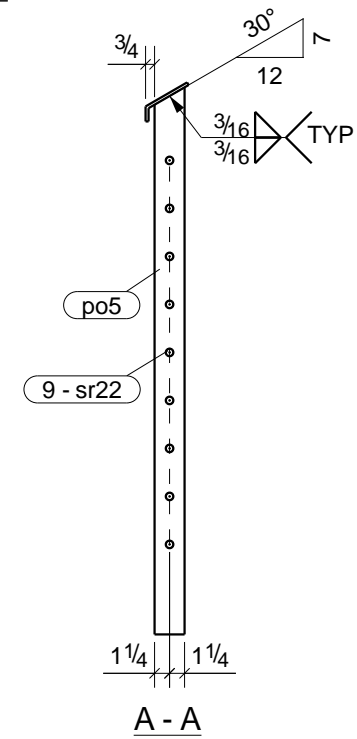

**ONE - GUARDRAIL - GR17**

DRAWING STATUS			
SHOP PAINT:	2.5 MILS DFT	13/16" Ø HOLES(U.N.O.)	ALL STEEL TO ASTM A36 U.N.O.
SHOP PRIME		3/4" BOLTS, ST (U.N.O.)	ALL WELD TO BE E70 LH (U.N.O.)
PROJECT: TRULIANT MONUMENTAL STAIR			DRAWN BY: DSA
DESCRIPTION: GUARDRAIL			CHECKED BY: RAD
ARCH:		ENG:	JOB NO:
CUSTOMER:			SHEET NO: GR17

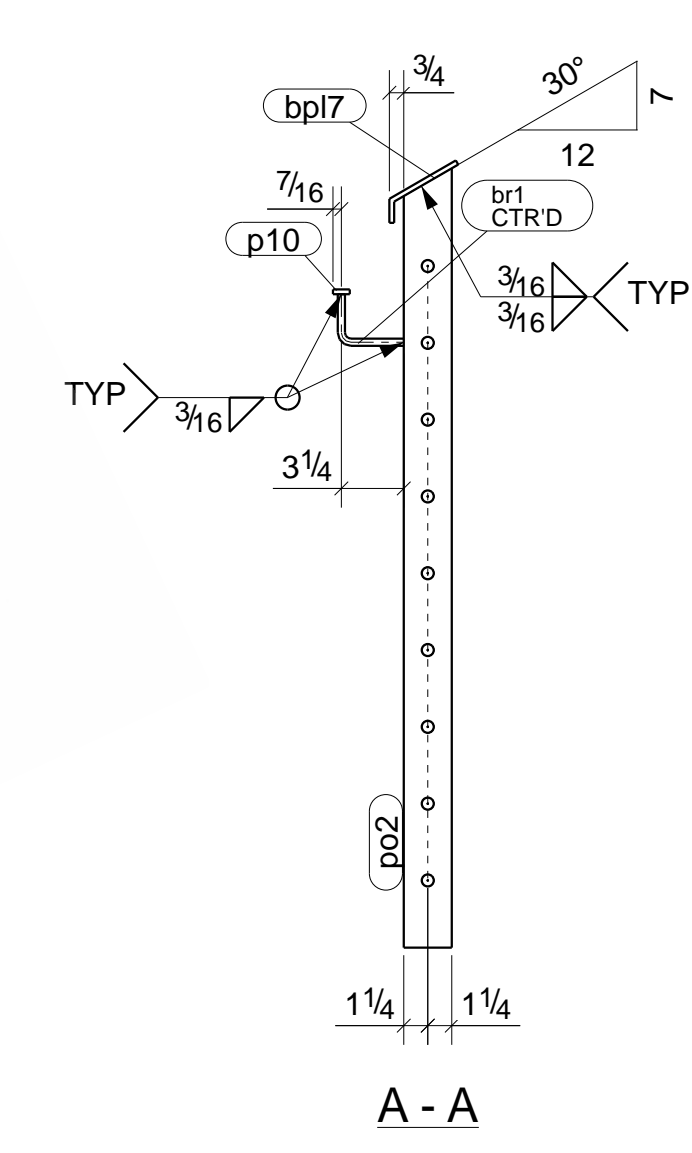
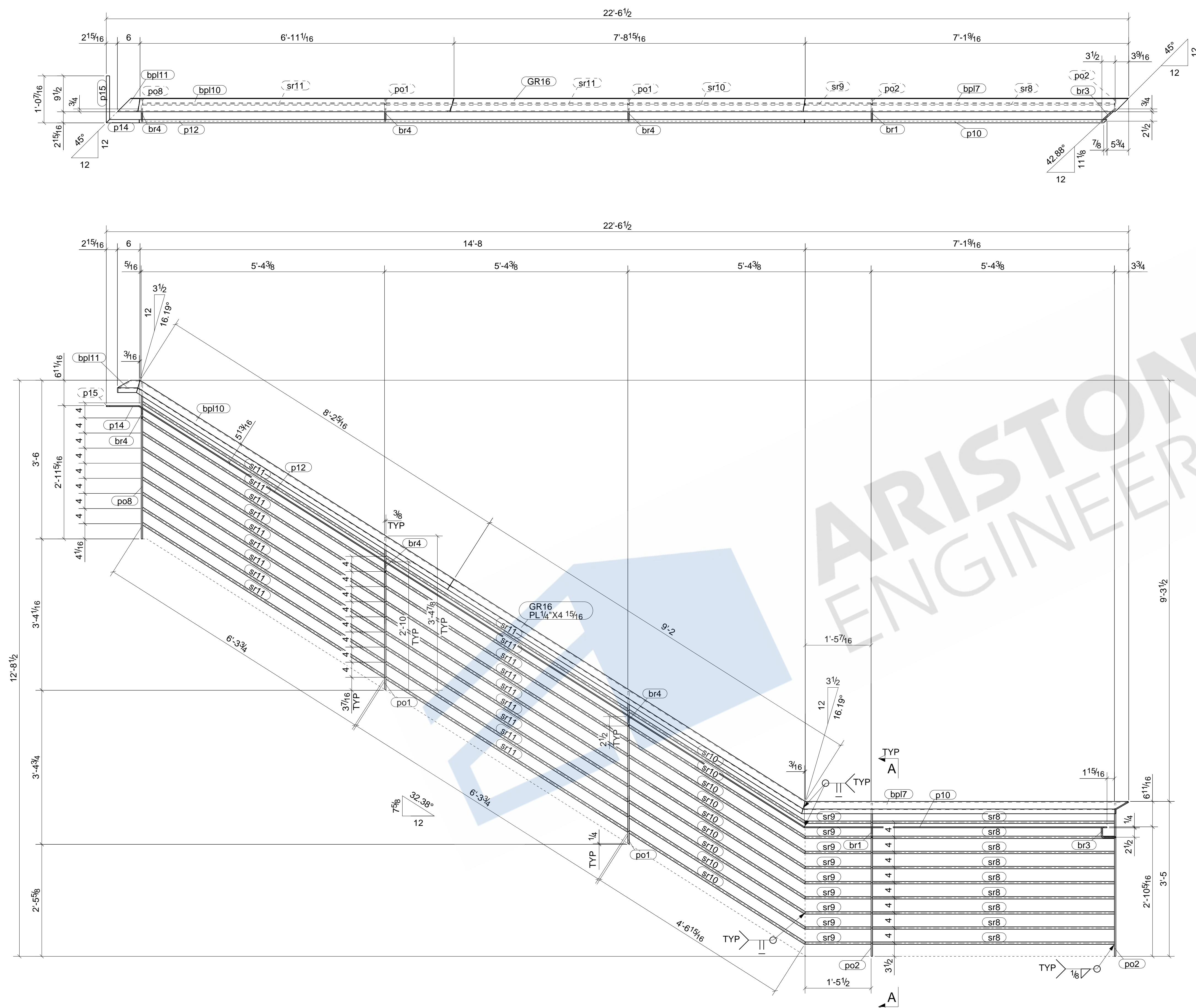

BILL OF MATERIAL					
MARK	QTY	DESCRIPTION	LENGTH	WEIGHT	REMARKS
GR16	1	GUARDRAIL			BEV-2
GR16	1	PL1/4"X4 15/16"	9'-4"	40	SHOP PRIME A36
bpl7	1	PL1/4"X4 15/16"	7'-5"	30	A36
bpl10	1	PL1/4"X4 15/16"	8'-4"	35	A36
bpl11	1	PL1/4"X4 15/16"	0'-7"	2	A36
br1	1	ROD3/8"	0'-5 9/16"	0	A36
br3	1	ROD3/8"	0'-7 1/4"	0	A36
br4	3	ROD3/8"	0'-5 5/8"	0	A36
p10	1	PL1/4"X7/8"	6'-8 1/8"	5	A36
p12	1	PL1/4"X7/8"	17'-4 7/16"	13	A36
p14	1	PL1/4"X7/8"	0'-8 3/4"	1	A36
p15	1	PL1/4"X7/8"	1'-0 7/16"	1	A36
po1	2	PL3/8"X2 1/2"	3'-4 5/8"	21	A36
po2	2	PL3/8"X2 1/2"	3'-4 5/8"	21	A36
po8	1	PL3/8"X2 1/2"	3'-5 5/16"	11	A36
sr8	9	ROD5/8"	5'-4"	45	A36
sr9	9	ROD5/8"	1'-5 9/16"	12	A36
sr10	9	ROD5/8"	4'-7 3/8"	39	A36
sr11	18	ROD5/8"	6'-4 1/8"	107	A36
TOTAL WEIGHT THIS DRAWING				383	

DRAWING STATUS			
SHOP PAINT:	2.5 MILS DFT	13/16" Ø HOLES (U.N.O.)	ALL STEEL TO ASTM A36 U.N.O.
SHOP PRIME		3/4" BOLTS, ST (U.N.O.)	ALL WELD TO BE E70 LH (U.N.O.)
PROJECT:	TRULIANT MONUMENTAL STAIR		DRAWN BY: DSA
DESCRIPTION:	GUARDRAIL		CHECKED BY: RAD
ARCH:	ENG:		JOB NO:
CUSTOMER:			SHEET NO: GR16

ONE - GUARDRAIL - GR16

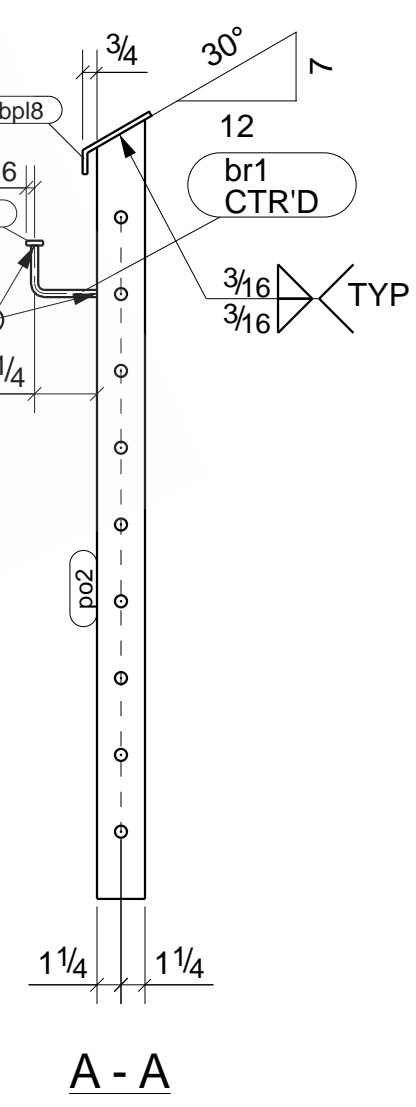
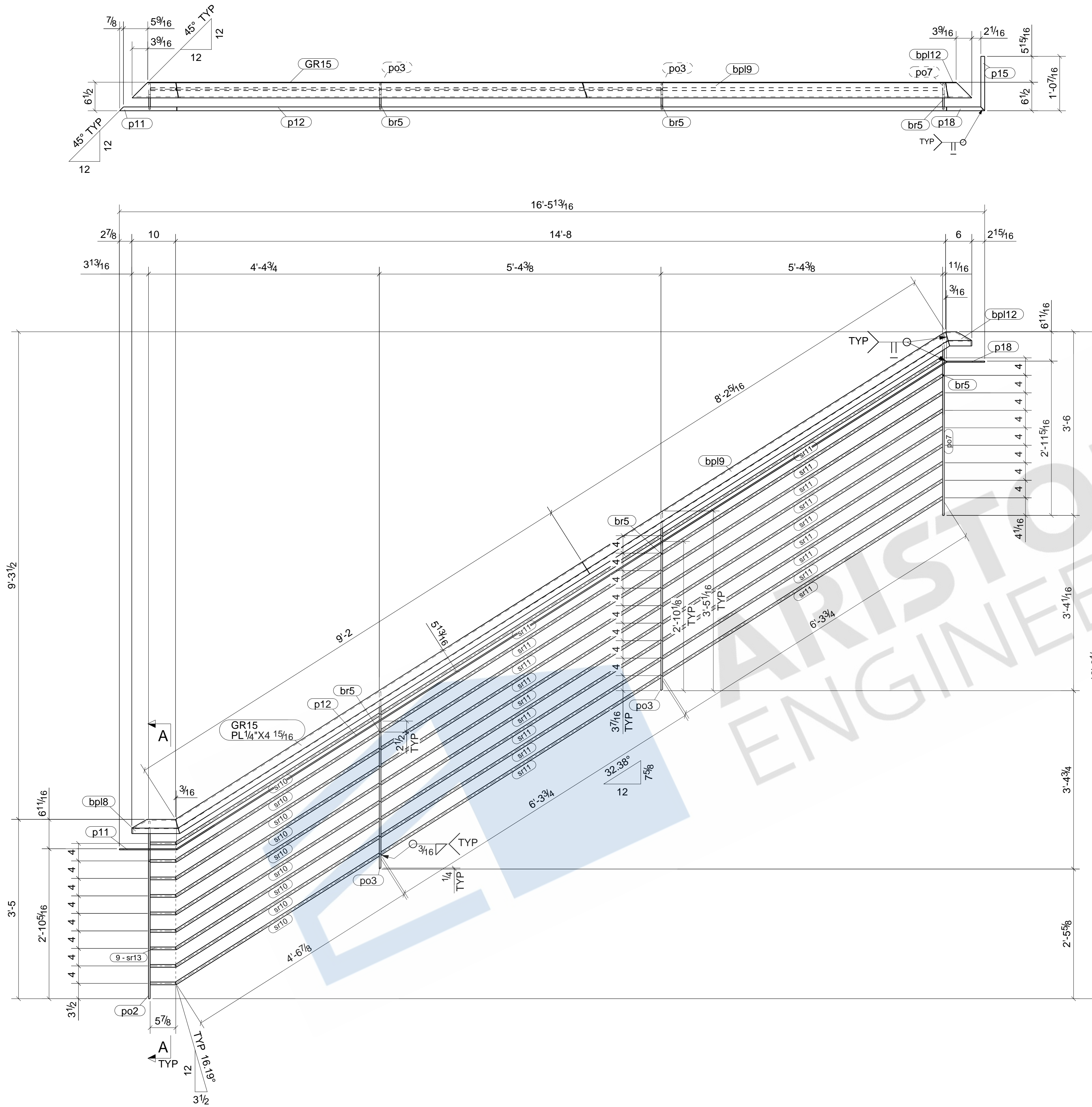

BILL OF MATERIAL					
MARK	QTY	DESCRIPTION	LENGTH	WEIGHT	REMARKS
GR15	1	GUARDRAIL			BEV-2
GR15	1	PL1/4\"/>			

ONE - GUARDRAIL - GR15

DRAWING STATUS			
SHOP PAINT:	2.5 MILS DFT	13/16\"/>	

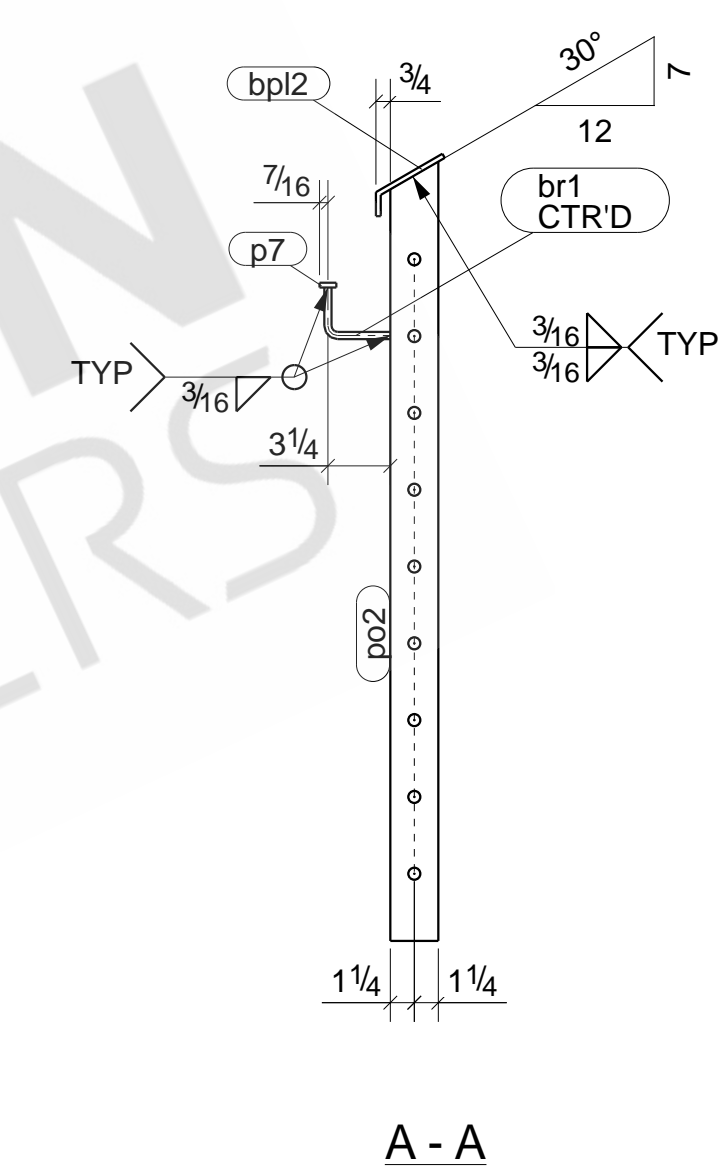
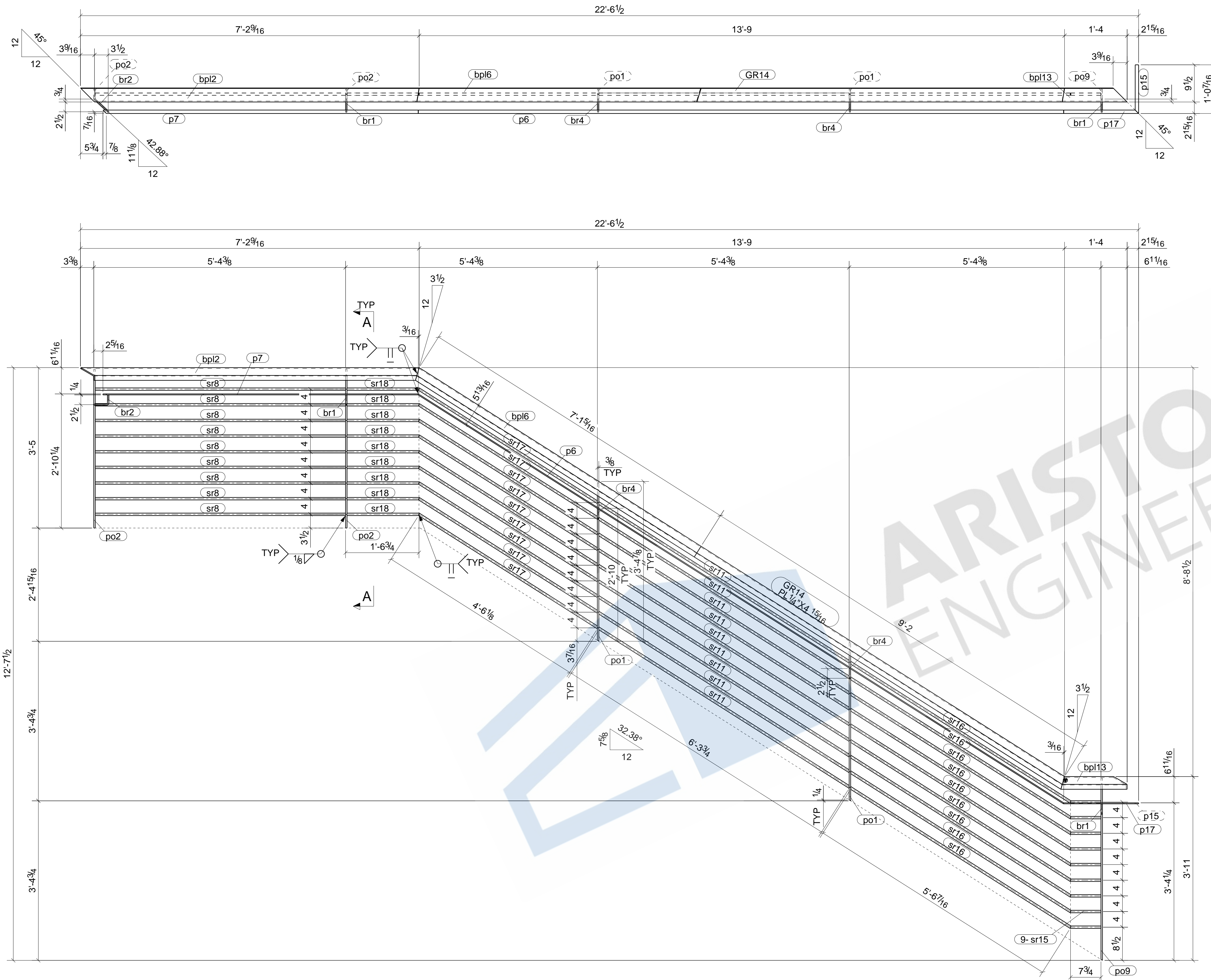

BILL OF MATERIAL					
MARK	QTY	DESCRIPTION	LENGTH	WEIGHT	REMARKS
GR14	1	GUARDRAIL			BEV-2
GR14	1	PL1/4"x4 15/16"	9'-4"	40	SHOP PRIME A36
bpl2	1	PL1/4"x4 15/16"	7'-5"	30	A36
bpl6	1	PL1/4"x4 15/16"	7'-3"	31	A36
bpl13	1	PL1/4"x4 15/16"	1'-7"	5	A36
br1	2	ROD3/8"	0'-5 9/16"	0	A36
br2	1	ROD3/8"	0'-7 1/4"	0	A36
br4	2	ROD3/8"	0'-5 5/8"	0	A36
p6	1	PL1/4"x7/8"	16'-3 3/8"	12	A36
p7	1	PL1/4"x7/8"	6'-8 5/8"	5	A36
p15	1	PL1/4"x7/8"	1'-0 7/16"	1	A36
p17	1	PL1/4"x7/8"	1'-7 3/16"	1	A36
po1	2	PL3/8"x2 1/2"	3'-4 5/8"	21	A36
po2	2	PL3/8"x2 1/2"	3'-4 9/16"	21	A36
po9	1	PL3/8"x2 1/2"	3'-10 9/16"	12	A36
sr8	9	ROD5/8"	5'-4"	45	A36
sr11	9	ROD5/8"	6'-4 1/8"	53	A36
sr15	9	ROD5/8"	0'-7 7/8"	5	A36
sr16	9	ROD5/8"	5'-6 13/16"	47	A36
sr17	9	ROD5/8"	4'-6 1/4"	38	A36
sr18	9	ROD5/8"	1'-6 1/2"	13	A36
TOTAL WEIGHT THIS DRAWING				383	

ONE - GUARDRAIL - GR14

DRAWING STATUS			
SHOP PAINT:	2.5 MILS DFT	13/16" Ø HOLES(U.N.O.)	ALL STEEL TO ASTM A36 U.N.O.
SHOP PRIME		3/4" BOLTS, ST (U.N.O.)	ALL WELD TO BE E70 LH (U.N.O.)
PROJECT:	TRULIANT MONUMENTAL STAIR		DRAWN BY: DSA
DESCRIPTION:	GUARDRAIL		CHECKED BY: RAD
ARCH:	ENG:		JOB NO:
CUSTOMER:			SHEET NO: GR14



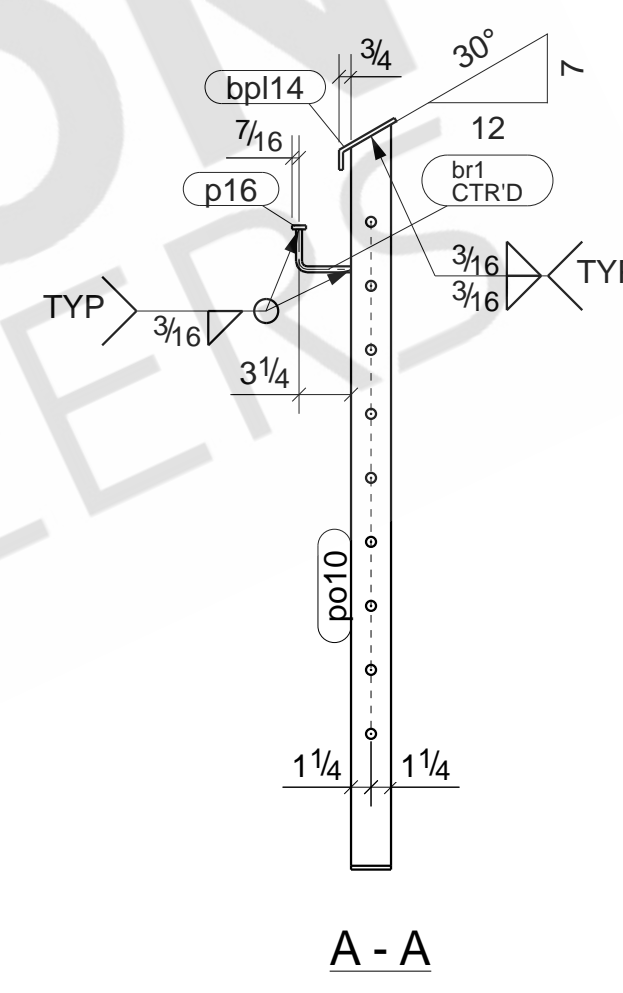
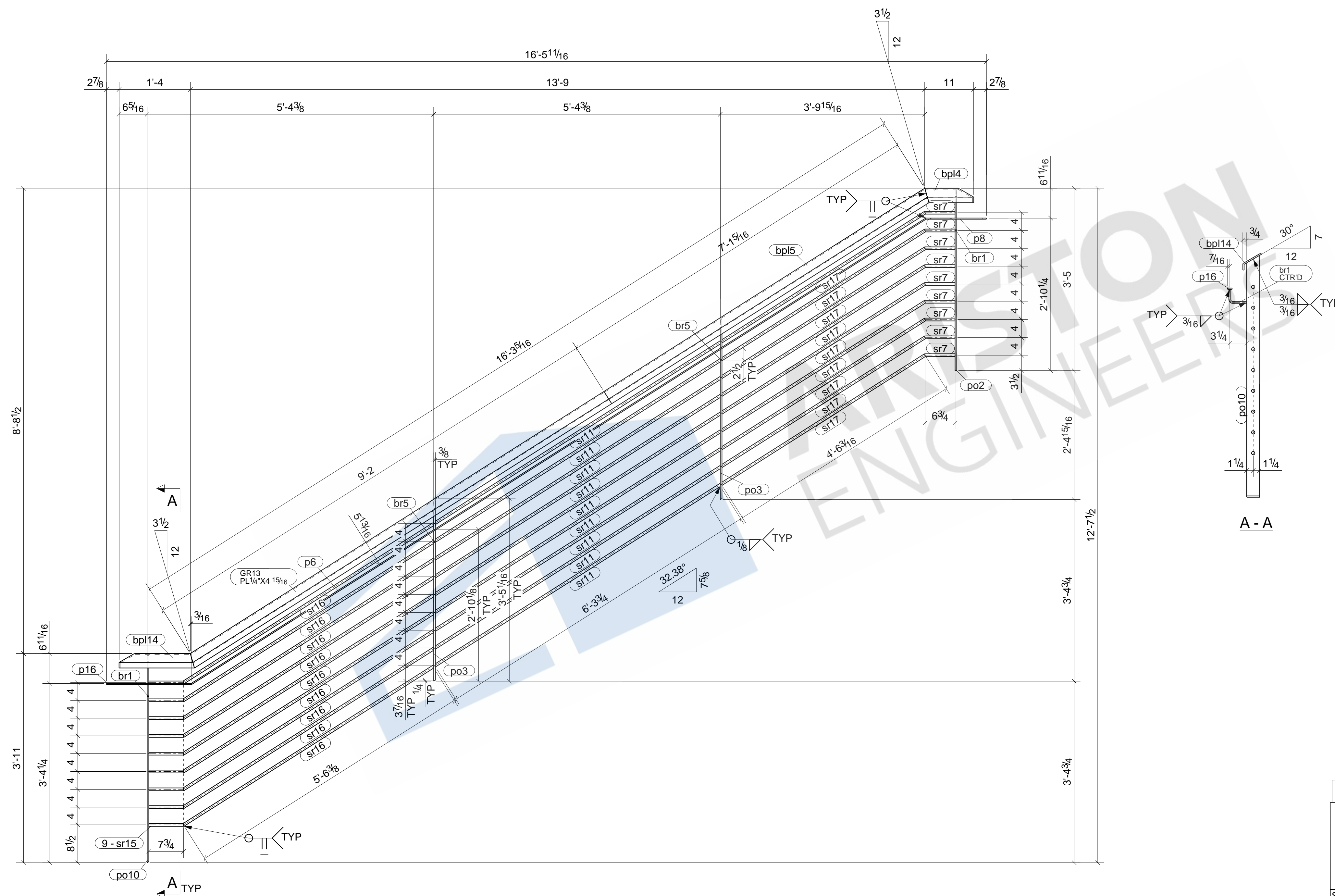
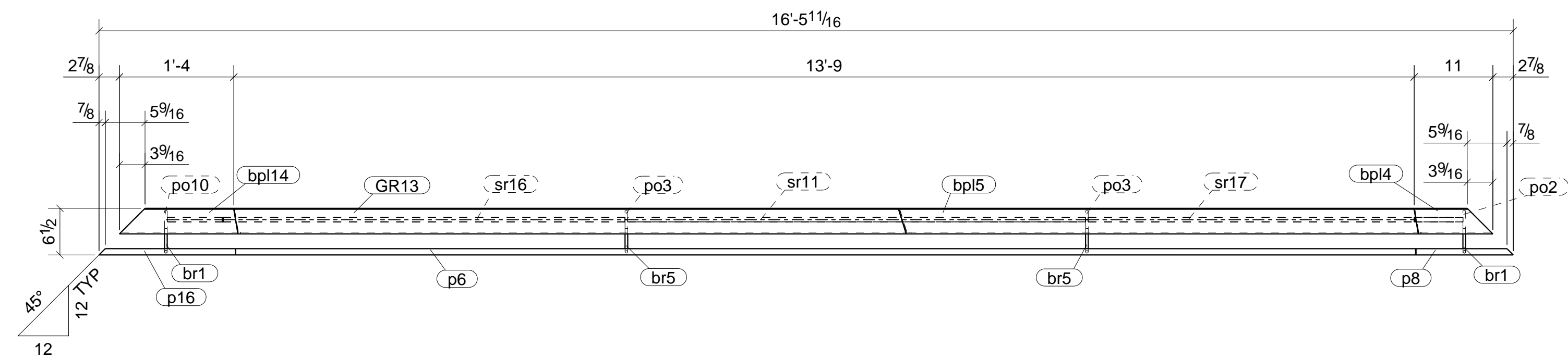

BILL OF MATERIAL					
MARK	QTY	DESCRIPTION	LENGTH	WEIGHT	REMARKS
GR13	1	GUARDRAIL			BEV-2
GR13	1	PL1/4"x4 15/16"	9'-4"	40	SHOP PRIME A36
bpl4	1	PL1/4"x4 15/16"	1'-1"	3	A36
bpl5	1	PL1/4"x4 15/16"	7'-3"	31	A36
bpl14	1	PL1/4"x4 15/16"	1'-7"	5	A36
br1	2	ROD3/8"	0'-5 9/16"	0	A36
br5	2	ROD3/8"	0'-5 5/8"	0	A36
p6	1	PL1/4"x7/8"	16'-3 3/8"	12	A36
p8	1	PL1/4"x7/8"	1'-1 5/8"	1	A36
p16	1	PL1/4"x7/8"	1'-7 1/8"	1	A36
po2	1	PL3/8"x2 1/2"	3'-4 9/16"	11	A36
po3	2	PL3/8"x2 1/2"	3'-4 5/8"	21	A36
po10	1	PL3/8"x2 1/2"	5'-10 9/16"	12	A36
sr7	9	ROD5/8"	0'-6 7/8"	5	A36
sr11	9	ROD5/8"	6'-4 1/8"	53	A36
sr15	9	ROD5/8"	0'-7 7/8"	5	A36
sr16	9	ROD5/8"	5'-6 13/16"	47	A36
sr17	9	ROD5/8"	4'-6 1/4"	38	A36
TOTAL WEIGHT THIS DRAWING				287	

ONE - GUARDRAIL - GR13

DRAWING STATUS			
SHOP PAINT:	2.5 MILS DFT	13/16" Ø HOLES (U.N.O.)	ALL STEEL TO ASTM A36 U.N.O.
SHOP PRIME		3/4" BOLTS, ST (U.N.O.)	ALL WELD TO BE E70 LH (U.N.O.)
PROJECT:	TRULIANT MONUMENTAL STAIR		DRAWN BY: DSA
DESCRIPTION:	GUARDRAIL		CHECKED BY: RAD
ARCH:	ENG:		JOB NO:
CUSTOMER:			SHEET NO: GR13

BILL OF MATERIAL					
MARK	QTY	DESCRIPTION	LENGTH	WEIGHT	REMARKS
GR12	4	GUARDRAILS			BEV-2
GR12	4	PL1/4"x4 15/16"	1'-7"	28	SHOP PRIME A36
po5	8	PL3/8"x2 1/2"	3'-9 9/16"	95	A36
sr20	36	RODS5/8"	1'-4 5/8"	47	A36
TOTAL WEIGHT THIS DRAWING				170	

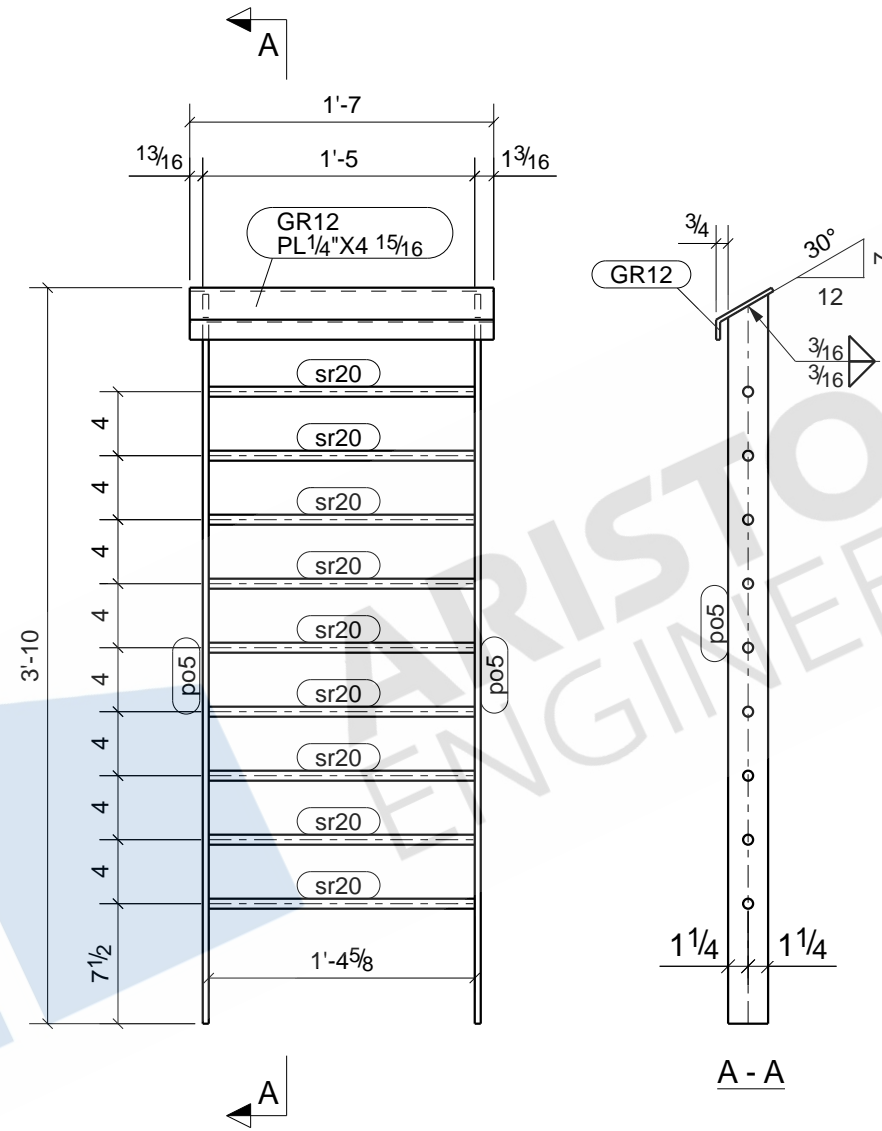

## 4 - GUARDRAILS - GR12

DRAWING STATUS			
SHOP PAINT:	2.5 MILS DFT	13/16" Ø HOLES(U.N.O.)	ALL STEEL TO ASTM A36 U.N.O.
SHOP PRIME		3/4" BOLTS, ST (U.N.O.)	ALL WELD TO BE E70 LH (U.N.O.)
PROJECT: TRULIANT MONUMENTAL STAIR			DRAWN BY: DSA
DESCRIPTION: GUARDRAIL			CHECKED BY: RAD
ARCH:	ENG:	JOB NO:	
CUSTOMER:			SHEET NO: GR12

BILL OF MATERIAL					
MARK	QTY	DESCRIPTION	LENGTH	WEIGHT	REMARKS
GR11	2	GUARDRAILS			BEV-2
GR11	2	PL1/4"x4 15/16"	10'-0"	87	SHOP PRIME A36
bpl15	2	PL1/4"x4 15/16"	5'-11"	51	A36
bpl16	2	PL1/4"x4 15/16"	5'-7"	48	A36
po5	10	PL3/8"x2 1/2"	3'-9 9/16"	119	A36
sr21	72	ROD5/8"	5'-3 5/8"	358	A36
TOTAL WEIGHT THIS DRAWING				665	

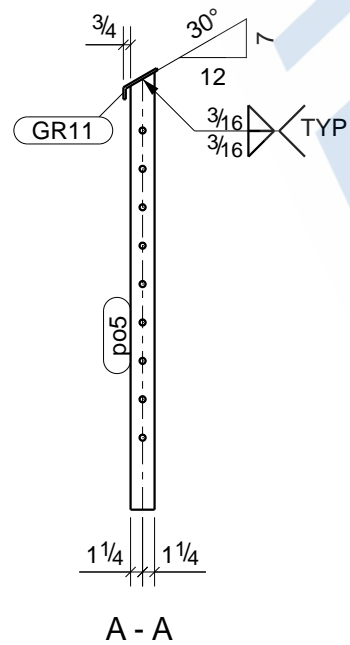
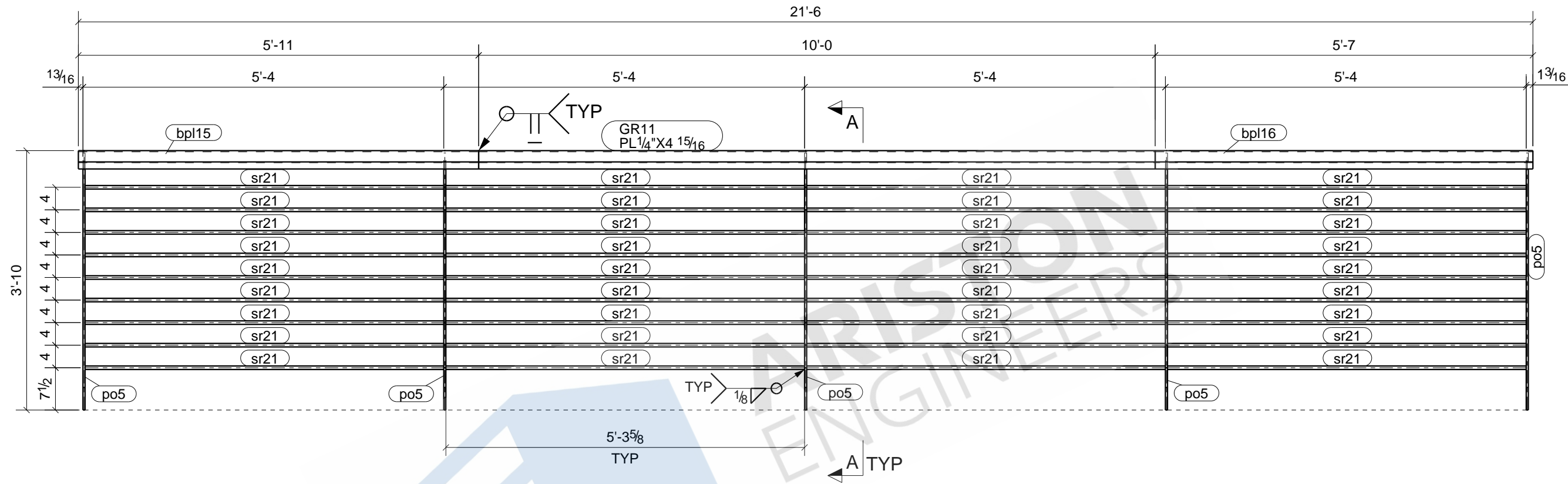

## 2 - GUARDRAILS - GR11

DRAWING STATUS			
SHOP PAINT:	2.5 MILS DFT	13/16" Ø HOLES(U.N.O.)	ALL STEEL TO ASTM A36 U.N.O.
SHOP PRIME		3/4" BOLTS, ST (U.N.O.)	ALL WELD TO BE E70 LH (U.N.O.)
PROJECT:	TRULIANT MONUMENTAL STAIR		
DESCRIPTION:	GUARDRAIL		
ARCH:	ENG:	JOB NO:	DRAWN BY: DSA
CUSTOMER:		SHEET NO:	CHECKED BY: RAD
			JOB NO:
			SHEET NO: GR11

BILL OF MATERIAL					
MARK	QTY	DESCRIPTION	LENGTH	WEIGHT	REMARKS
GR10	2	GUARDRAILS			BEV-2
GR10	2	PL1/4"x4 15/16"	10'-0"	87	SHOP PRIME A36
bpl1	2	PL1/4"x4 15/16"	5'-7"	48	SHOP PRIME A36
bpl15	2	PL1/4"x4 15/16"	5'-11"	51	A36
po5	10	PL3/8"x2 1/2"	3'-9 9/16"	119	A36
sr21	72	ROD5/8"	5'-3 5/8"	358	A36
TOTAL WEIGHT THIS DRAWING				665	

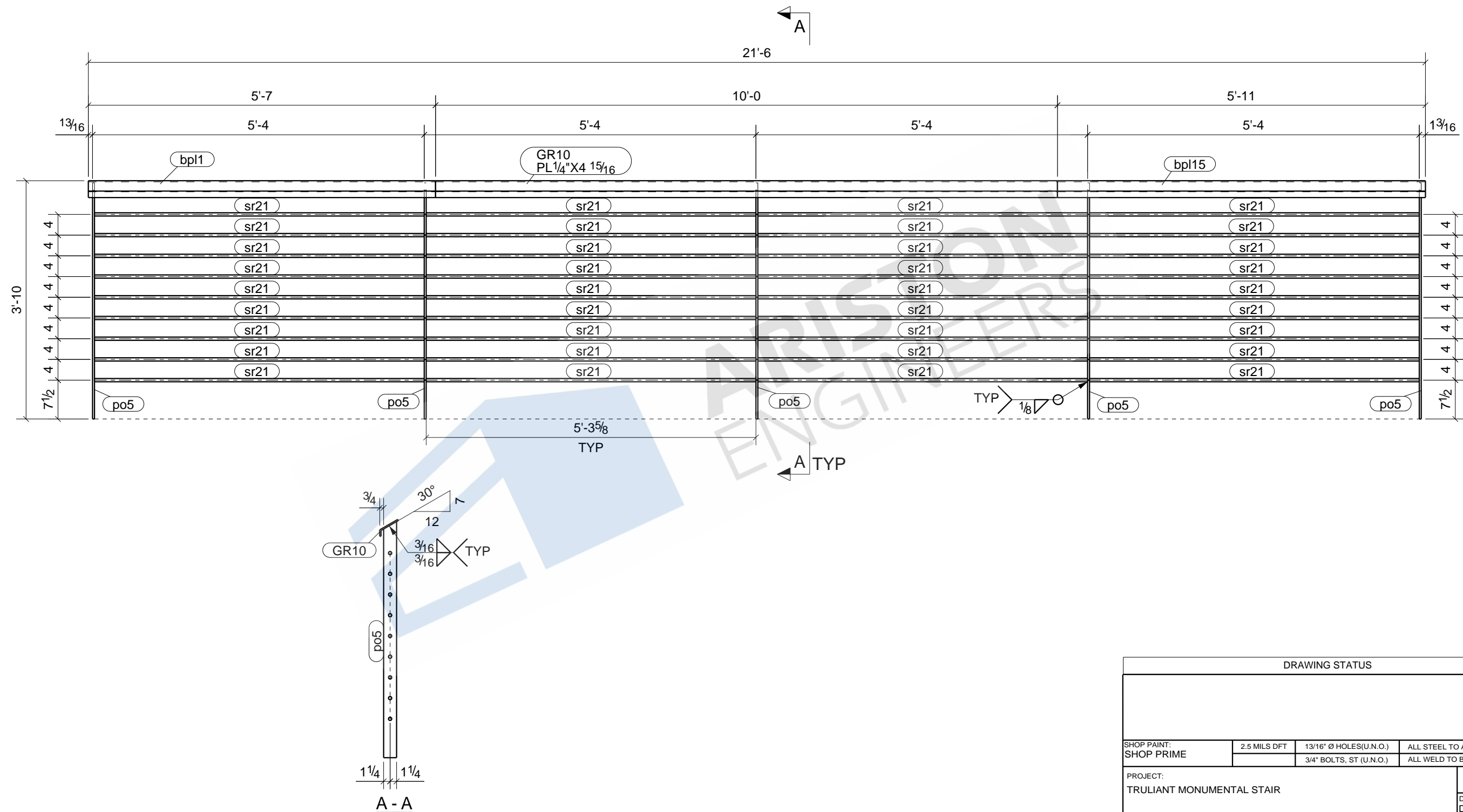

## 2 - GUARDRAILS - GR10

DRAWING STATUS			
SHOP PAINT:	2.5 MILS DFT	13/16" Ø HOLES(U.N.O.)	ALL STEEL TO ASTM A36 U.N.O.
SHOP PRIME		3/4" BOLTS, ST (U.N.O.)	ALL WELD TO BE E70 LH (U.N.O.)
PROJECT:	TRULIANT MONUMENTAL STAIR		
DESCRIPTION:	GUARDRAIL		
ARCH:	ENG:	JOB NO:	DRAWN BY: DSA
CUSTOMER:		SHEET NO:	RAD
			JOB NO:
			SHEET NO: GR10

BILL OF MATERIAL					
MARK	QTY	DESCRIPTION	LENGTH	WEIGHT	REMARKS
GR9	1	GUARDRAIL			BEV-2
GR9	1	PL1/4"x4 15/16"	1'-11"	8	SHOP PRIME A36
po5	2	PL3/8"x2 1/2"	3'-9 9/16"	24	A36
sr19	9	RODS5/8"	1'-5 5/8"	12	A36
TOTAL WEIGHT THIS DRAWING				44	

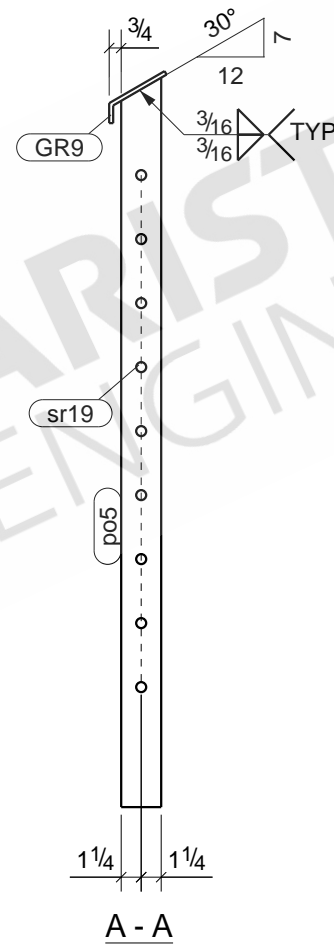
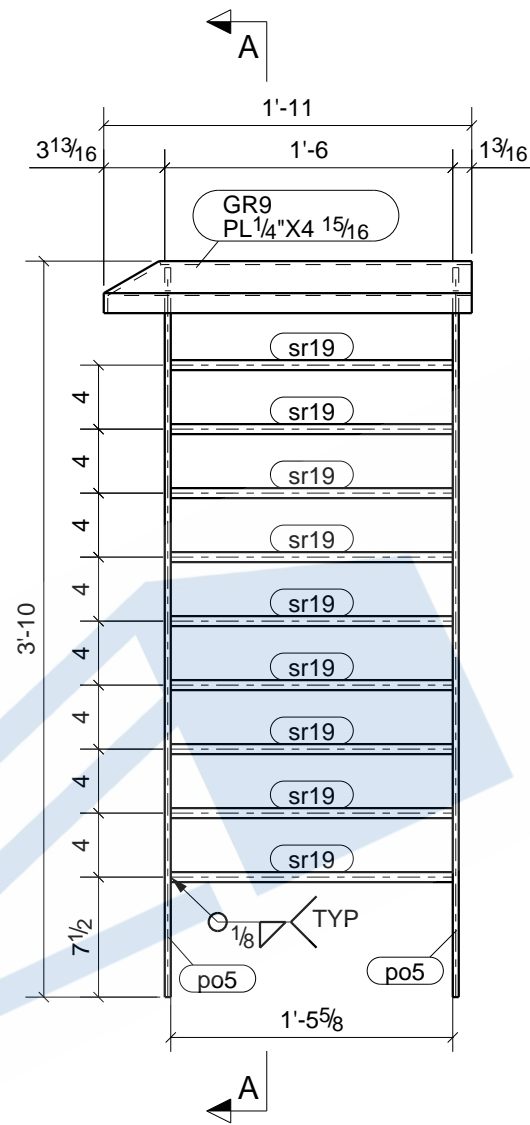
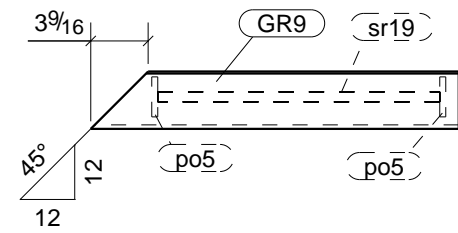

## ONE - GUARDRAIL - GR9

DRAWING STATUS			
SHOP PAINT:	2.5 MILS DFT	13/16" Ø HOLES(U.N.O.)	ALL STEEL TO ASTM A36 U.N.O.
SHOP PRIME		3/4" BOLTS, ST (U.N.O.)	ALL WELD TO BE E70 LH (U.N.O.)
PROJECT: TRULIANT MONUMENTAL STAIR			DRAWN BY: DSA
DESCRIPTION: GUARDRAIL			CHECKED BY: RAD
ARCH:	ENG:	JOB NO:	
CUSTOMER:			SHEET NO: GR9

BILL OF MATERIAL					
MARK	QTY	DESCRIPTION	LENGTH	WEIGHT	REMARKS
GR8	2	GUARDRAILS			BEV-2
GR8	2	PL1/4"x4 15/16"	1'-11"	16	SHOP PRIME A36
po5	4	PL3/8"x2 1/2"	3'-9 9/16"	48	A36
sr19	18	RODS5/8"	1'-6 5/8"	25	A36
TOTAL WEIGHT THIS DRAWING				88	

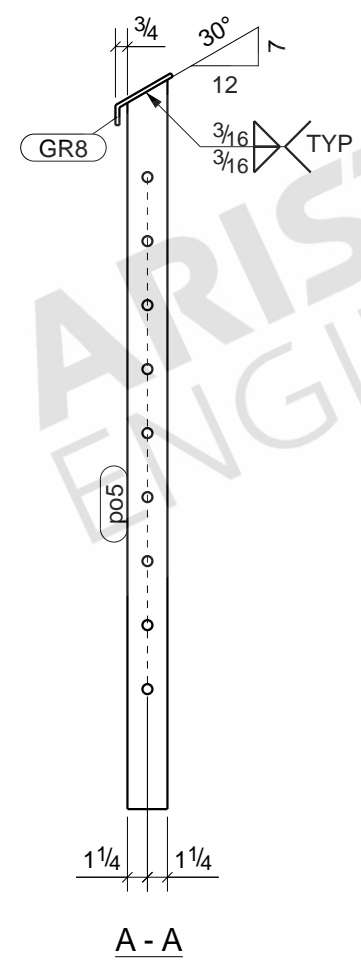
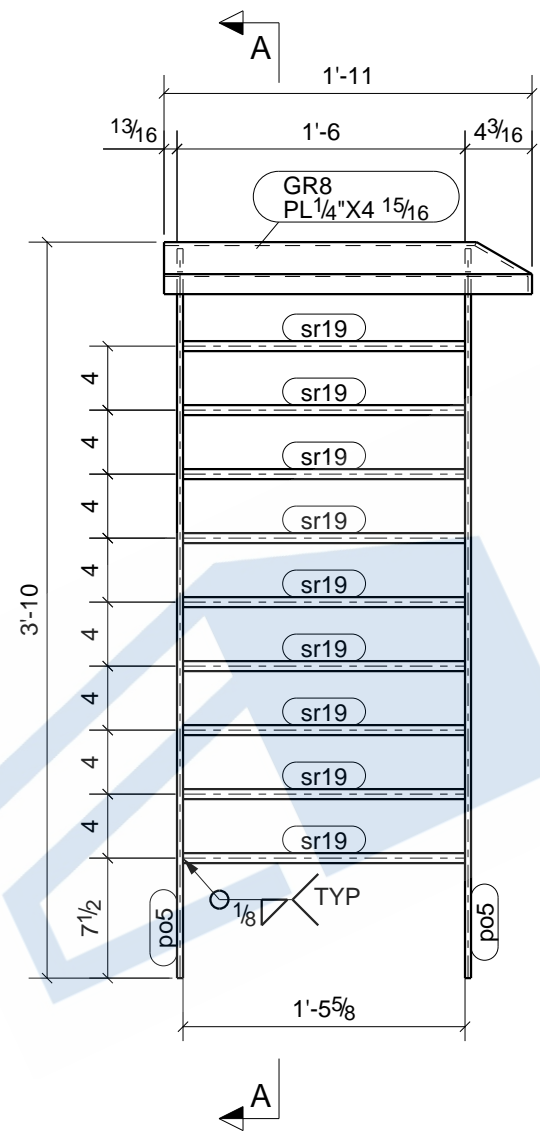
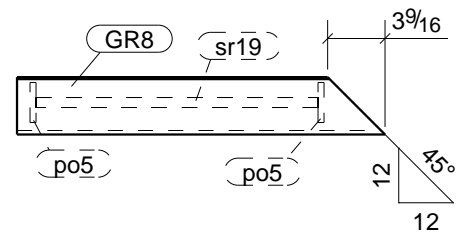

**2 - GUARDRAILS - GR8**

DRAWING STATUS			
SHOP PAINT:	2.5 MILS DFT	13/16" Ø HOLES(U.N.O.)	ALL STEEL TO ASTM A36 U.N.O.
SHOP PRIME		3/4" BOLTS, ST (U.N.O.)	ALL WELD TO BE E70 LH (U.N.O.)
PROJECT:	TRULIANT MONUMENTAL STAIR		
DESCRIPTION:	GUARDRAIL		
ARCH:	ENG:	JOB NO:	DRAWN BY: DSA
CUSTOMER:		SHEET NO:	RAD
			CHECKED BY: RAD
			JOB NO:
			SHEET NO: GR8









BILL OF MATERIAL					
MARK	QTY	DESCRIPTION	LENGTH	WEIGHT	REMARKS
GR4	2	GUARDRAILS			BEV-2
GR4	2	PL1/4"x4 15/16"	9'-2"	78	SHOP PRIME A36
bpl3	2	PL1/4"x4 15/16"	9'-2"	78	A36
br1	4	ROD3/8"	0'-5 9/16"	1	A36
br2	2	ROD3/8"	0'-7 1/4"	0	A36
br3	2	ROD3/8"	0'-7 1/4"	0	A36
p9	2	PL1/4"x7/8"	17'-3 11/16"	28	A36
po2	8	PL3/8"x2 1/2"	3'-4 9/16"	85	A36
sr5	54	ROD5/8"	5'-10 5/16"	297	A36
TOTAL WEIGHT THIS DRAWING				565	

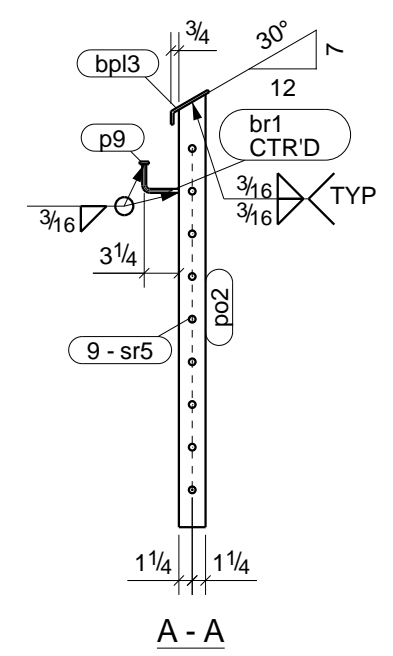
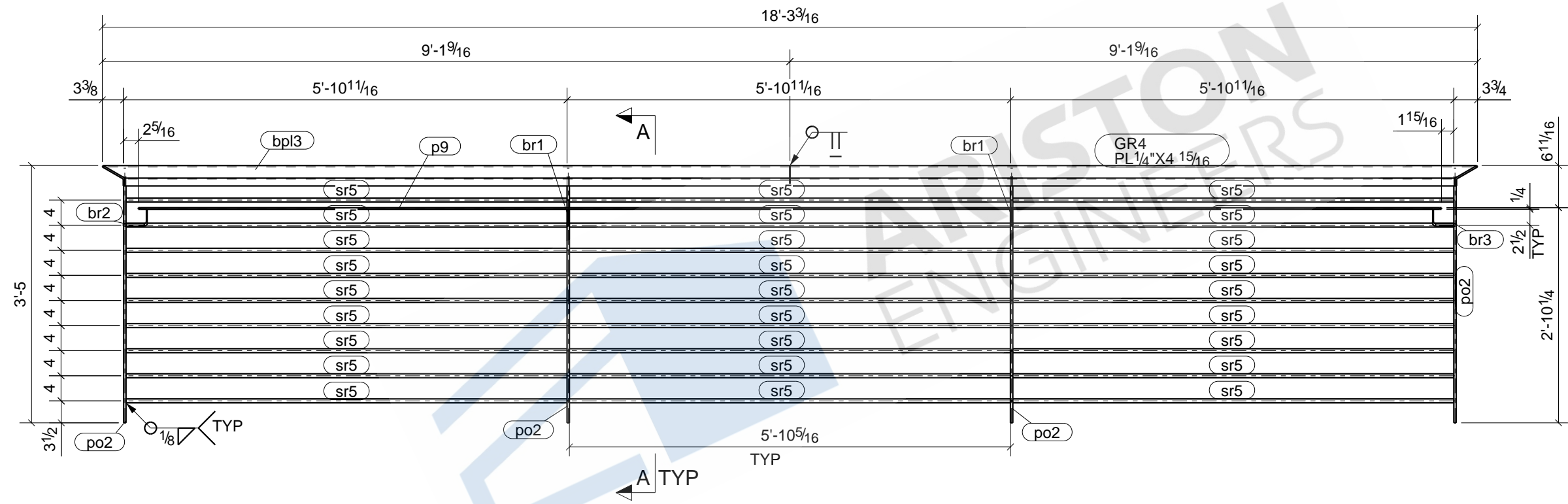
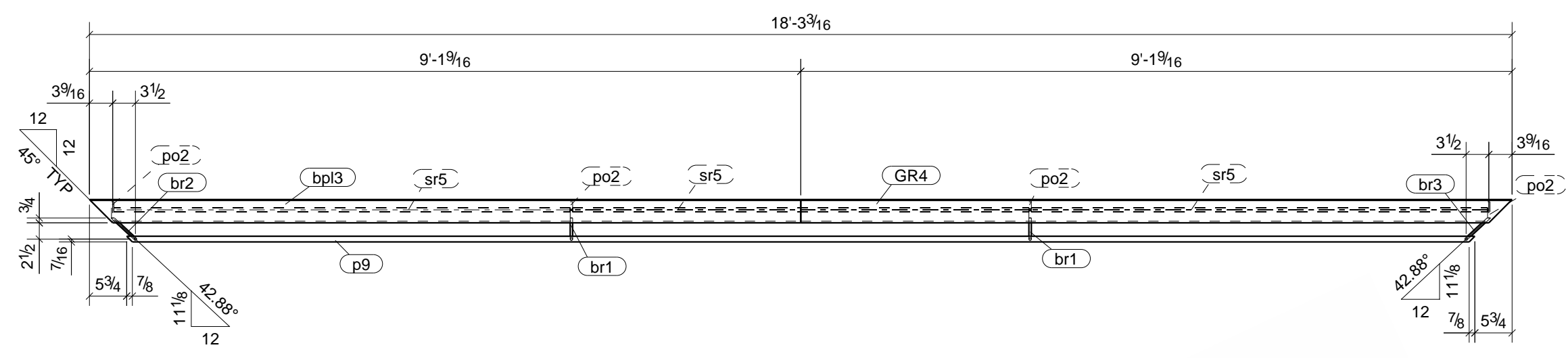

DRAWING STATUS			
SHOP PAINT:	2.5 MILS DFT	13/16" Ø HOLES(U.N.O.)	ALL STEEL TO ASTM A36 U.N.O.
SHOP PRIME		3/4" BOLTS, ST (U.N.O.)	ALL WELD TO BE E70 LH (U.N.O.)
PROJECT: TRULIANT MONUMENTAL STAIR			DRAWN BY: DSA
DESCRIPTION: GUARDRAIL			CHECKED BY: RAD
ARCH:	ENG:	JOB NO:	
CUSTOMER:			SHEET NO: GR4

**2 - GUARDRAILS - GR4**

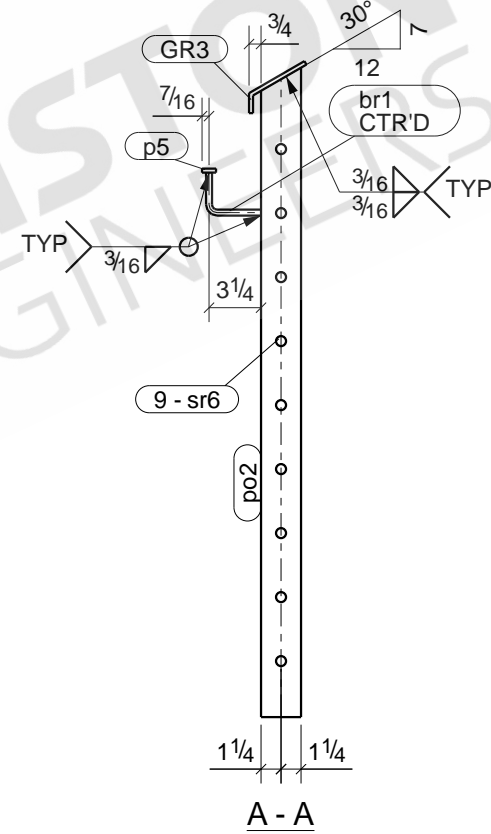
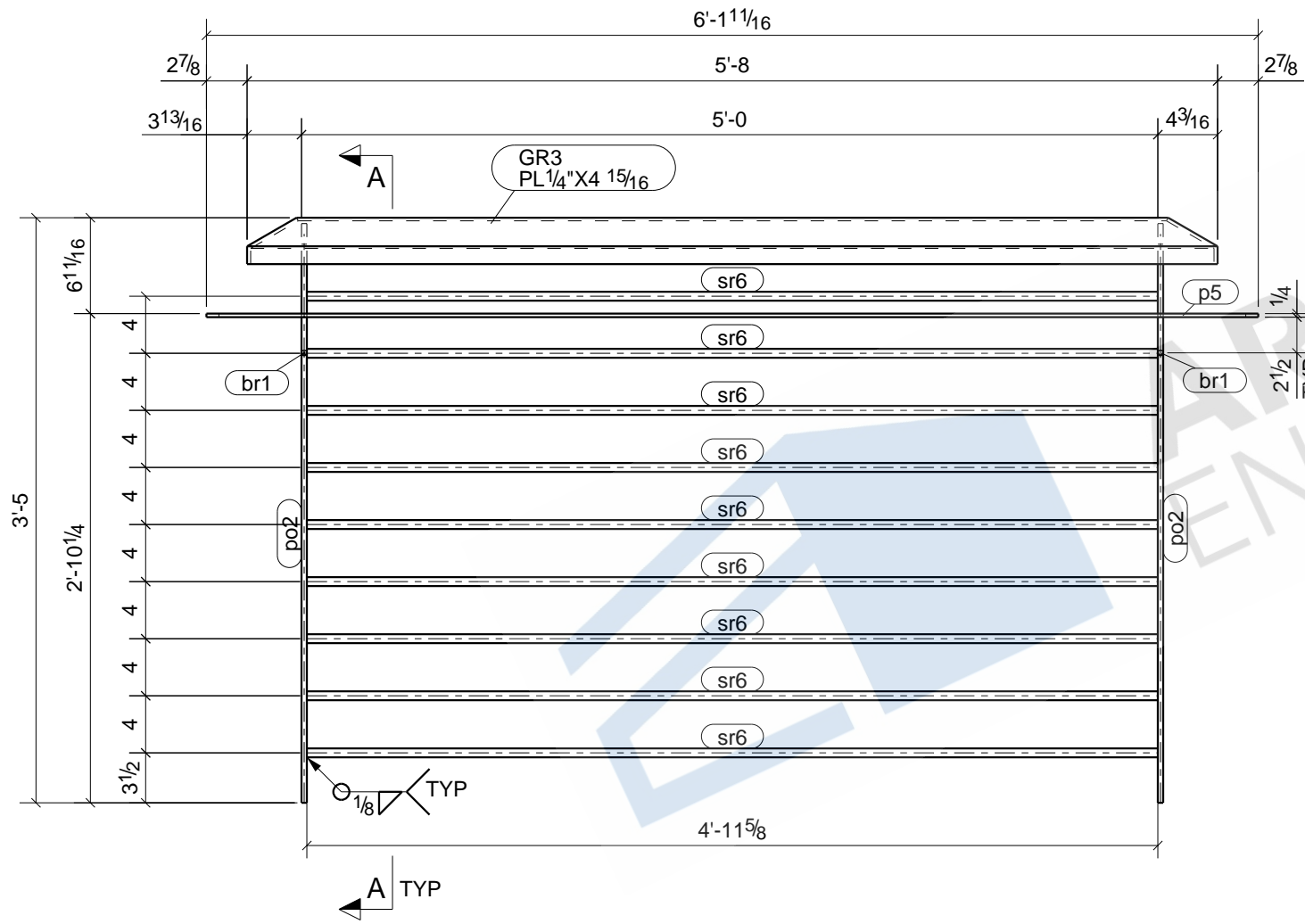
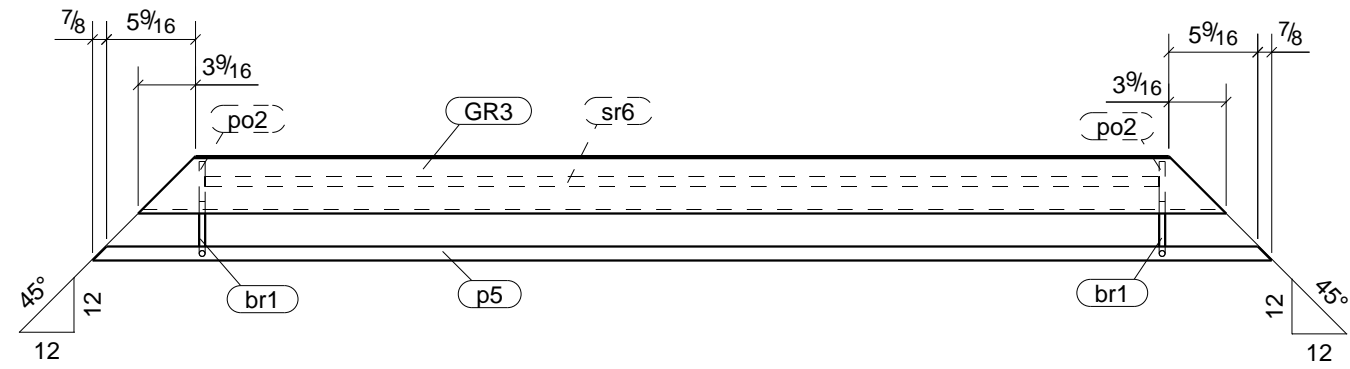

BILL OF MATERIAL					
MARK	QTY	DESCRIPTION	LENGTH	WEIGHT	REMARKS
GR3	2	GUARDRAILS			BEV-2
GR3	2	PL1/4\"X4 15 1/16\"	5'-8\"	47	SHOP PRIME A36
br1	4	R003/8\"	0'-5 9/16\"	1	A36
p5	2	PL1/4\"X7/8\"	6'-1 11/16\"	9	A36
po2	4	PL3/8\"X2 1/2\"	3'-4 9/16\"	42	A36
sr6	18	R005/8\"	4'-11 5/8\"	84	A36
TOTAL WEIGHT THIS DRAWING				183	

DRAWING STATUS			
SHOP PAINT:	2.5 MILS DFT	13/16\" Ø HOLES(U.N.O.)	ALL STEEL TO ASTM A36 U.N.O.
SHOP PRIME		3/4\" BOLTS, ST (U.N.O.)	ALL WELD TO BE E70 LH (U.N.O.)
PROJECT: TRULIANT MONUMENTAL STAIR			DRAWN BY: DSA
DESCRIPTION: GUARDRAIL			CHECKED BY: RAD
ARCH:	ENG:	JOB NO:	
CUSTOMER:			SHEET NO: GR3

## 2 - GUARDRAILS - GR3

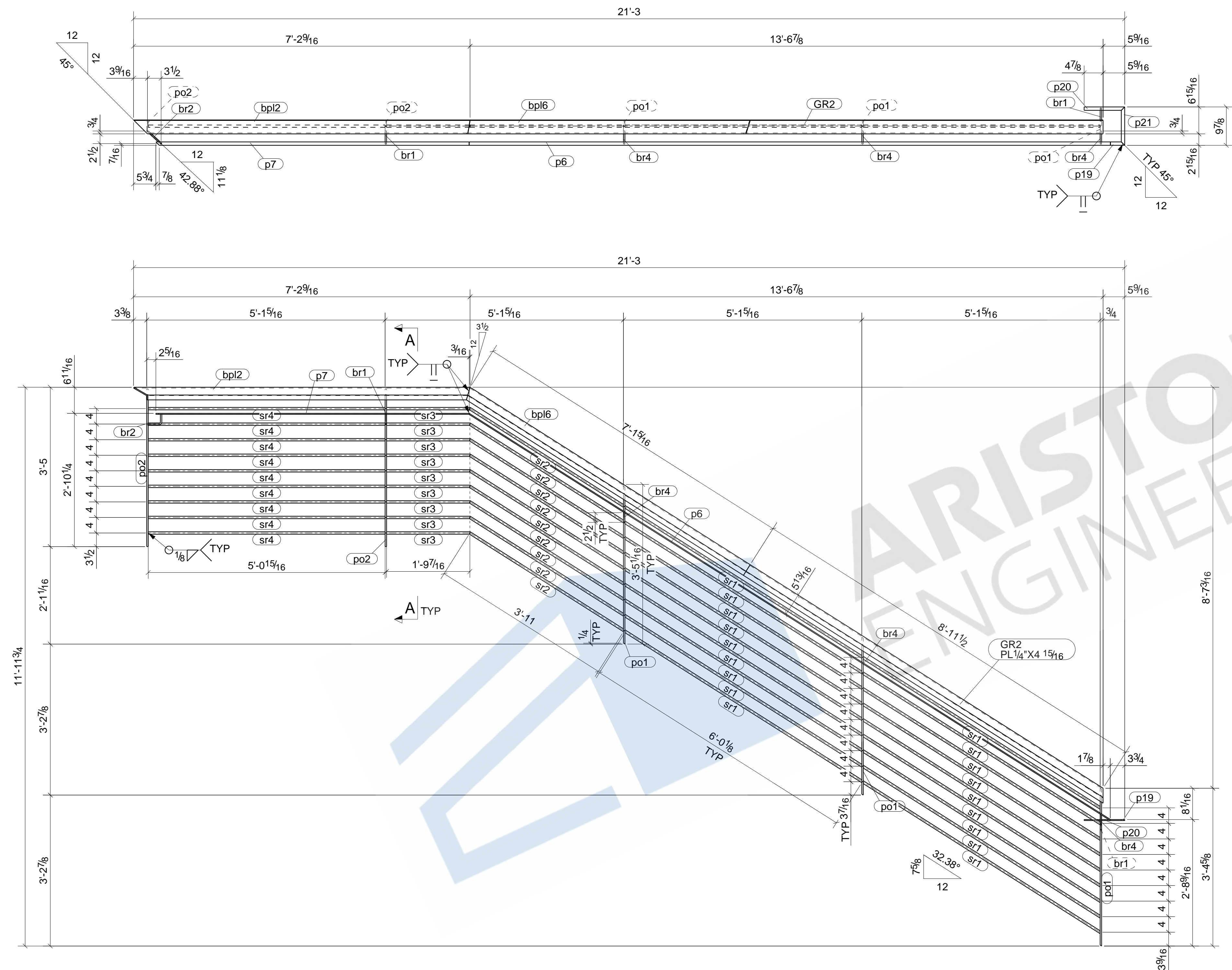

BILL OF MATERIAL					
MARK	QTY	DESCRIPTION	LENGTH	WEIGHT	REMARKS
GR2	1	GUARDRAIL			BEV-2
GR2	1	PL1/4"x4 15/16"	9'-4"	39	SHOP PRIME A36
bpl2	1	PL1/4"x4 15/16"	7'-5"	30	A36
bpl6	1	PL1/4"x4 15/16"	7'-3"	31	A36
br1	2	ROD3/8"	0'-5 9/16"	0	A36
br2	1	ROD3/8"	0'-7 1/4"	0	A36
br4	3	ROD3/8"	0'-5 5/8"	0	A36
p6	1	PL1/4"x7/8"	16'-3 3/8"	12	A36
p7	1	PL1/4"x7/8"	6'-8 5/8"	5	A36
p19	1	PL1/4"x7/8"	0'-3 3/4"	0	A36
p20	1	PL1/4"x7/8"	0'-10 7/16"	1	A36
p21	1	PL1/4"x7/8"	0'-9 7/8"	1	A36
po1	3	PL3/8"x2 1/2"	3'-4 5/8"	32	A36
po2	2	PL3/8"x2 1/2"	3'-4 9/16"	21	A36
sr1	18	ROD5/8"	6'-0 9/16"	102	A36
sr2	9	ROD5/8"	3'-11 1/16"	33	A36
sr3	9	ROD5/8"	1'-9 1/2"	15	A36
sr4	9	ROD5/8"	5'-0 15/16"	43	A36
TOTAL WEIGHT THIS DRAWING				365	

ONE - GUARDRAIL - GR2

DRAWING STATUS			
SHOP PAINT:	2.5 MILS DFT	13/16" Ø HOLES(U.N.O.)	ALL STEEL TO ASTM A36 U.N.O.
SHOP PRIME		3/4" BOLTS, ST (U.N.O.)	ALL WELD TO BE E70 LH (U.N.O.)
PROJECT:	TRULIANT MONUMENTAL STAIR		DRAWN BY: DSA
DESCRIPTION:	GUARDRAIL		CHECKED BY: RAD
ARCH:	ENG:		JOB NO:
CUSTOMER:			SHEET NO: GR2

### BILL OF MATERIAL

MARK	QTY	DESCRIPTION	LENGTH	WEIGHT	REMARKS
GR1	1	GUARDRAIL			BEV-2
GR1	1	PL1/4"x4 15/16"	9'-4"	39	SHOP PRIME A36
bpl4	1	PL1/4"x4 15/16"	1'-1"	3	A36
bpl5	1	PL1/4"x4 15/16"	7'-3"	31	A36
br1	2	ROD3/8"	0'-5 9/16"	0	A36
br5	3	ROD3/8"	0'-5 5/8"	0	A36
p6	1	PL1/4"x7/8"	16'-3 3/8"	12	A36
p8	1	PL1/4"x7/8"	1'-1 5/8"	1	A36
p20	1	PL1/4"x7/8"	0'-10 7/16"	1	A36
p21	1	PL1/4"x7/8"	0'-9 7/8"	1	A36
p22	1	PL1/4"x7/8"	0'-3 3/4"	0	A36
po3	1	PL3/8"x2 1/2"	3'-4 9/16"	11	A36
po2	3	PL3/8"x2 1/2"	3'-4 5/8"	32	A36
sr1	18	ROD5/8"	6'-0 9/16"	102	A36
sr2	9	ROD5/8"	3'-11 1/16"	33	A36
sr7	9	ROD5/8"	0'-6 7/8"	5	A36
TOTAL WEIGHT THIS DRAWING				270	

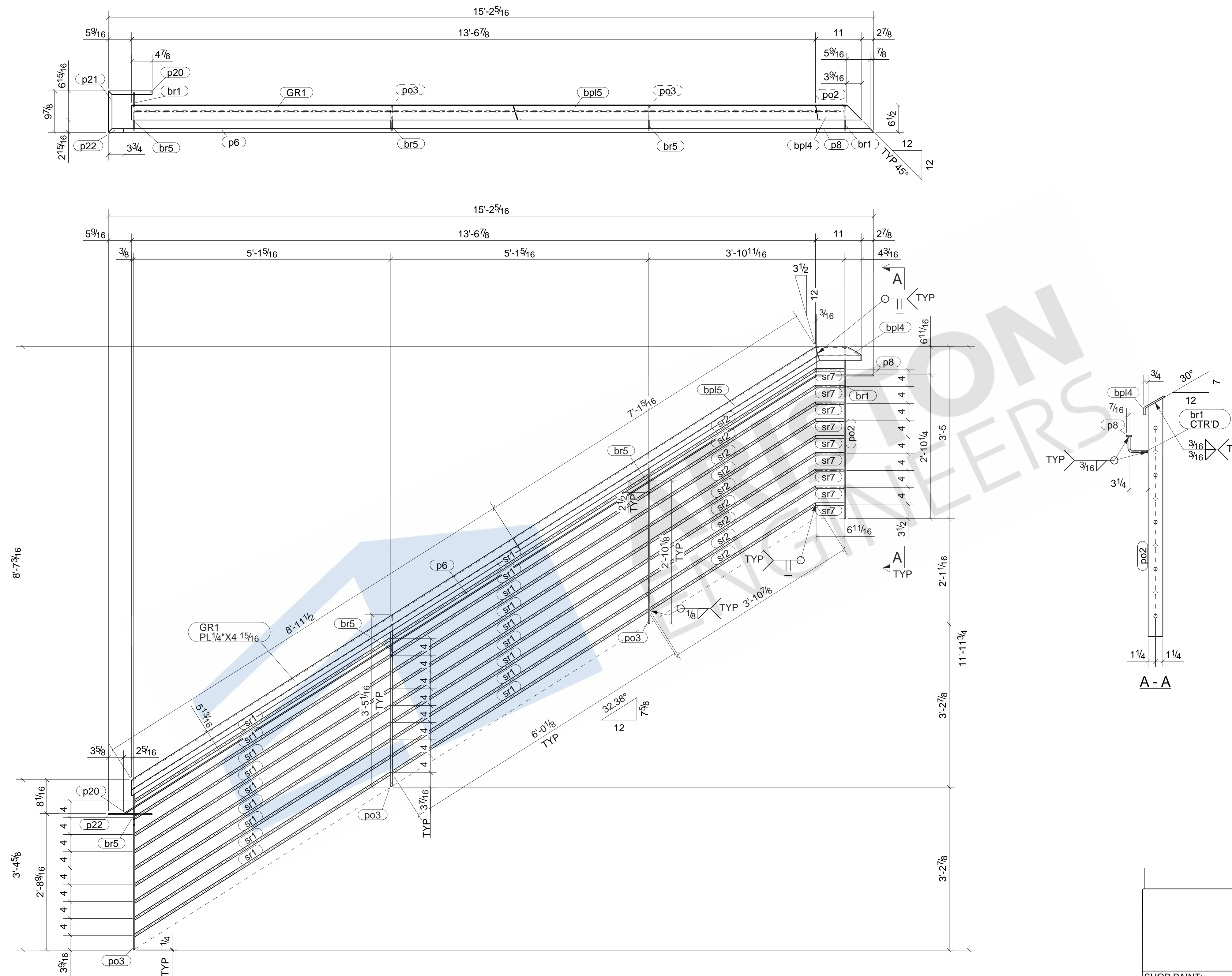

ONE - GUARDRAIL - GR1

### DRAWING STATUS

SHOP PAINT:				
SHOP PRIME	2.5 MILS DFT	13/16" Ø HOLES (U.N.O.)	ALL STEEL TO ASTM A36 U.N.O.	
		3/4" BOLTS, ST (U.N.O.)	ALL WELD TO BE E70 LH (U.N.O.)	
PROJECT:			DRAWN BY:	
TRULIANT MONUMENTAL STAIR				DSA
DESCRIPTION:			CHECKED BY:	
GUARDRAIL				RAD
ARCH:		ENG:	JOB NO:	
CUSTOMER:			SHEET NO:	
			GR1	

BILL OF MATERIAL					
MARK	QTY	DESCRIPTION	LENGTH	WEIGHT	REMARKS
TRD4	2	LANDING PANS			SQ-2
TRD4	2	PL5/16"X74"	7'-11 5/16"	1242	NO PAINT A36
TOTAL WEIGHT THIS DRAWING				1242	

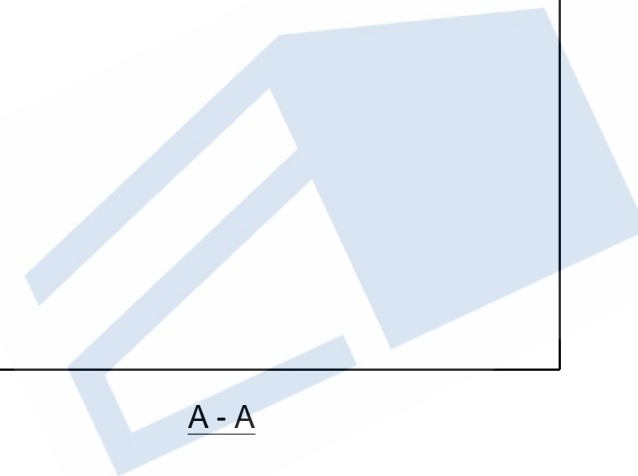
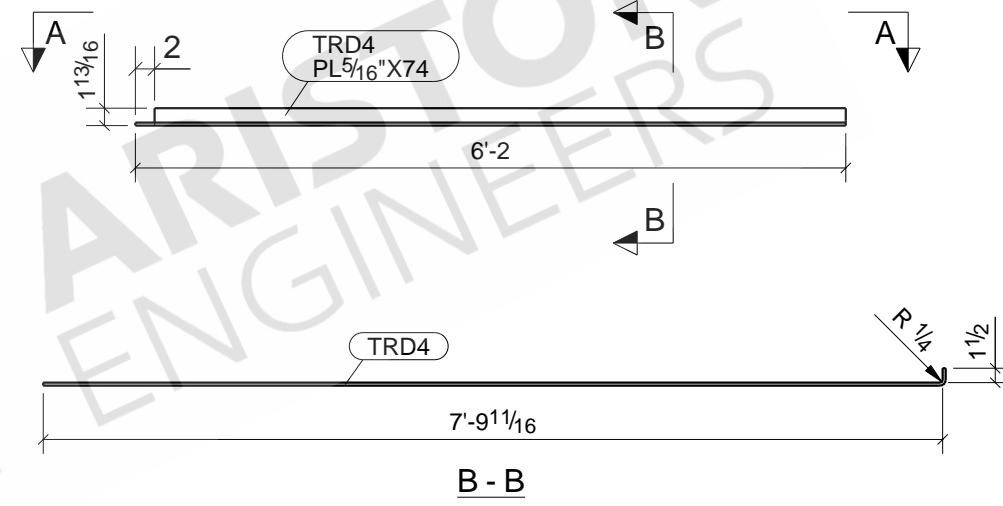
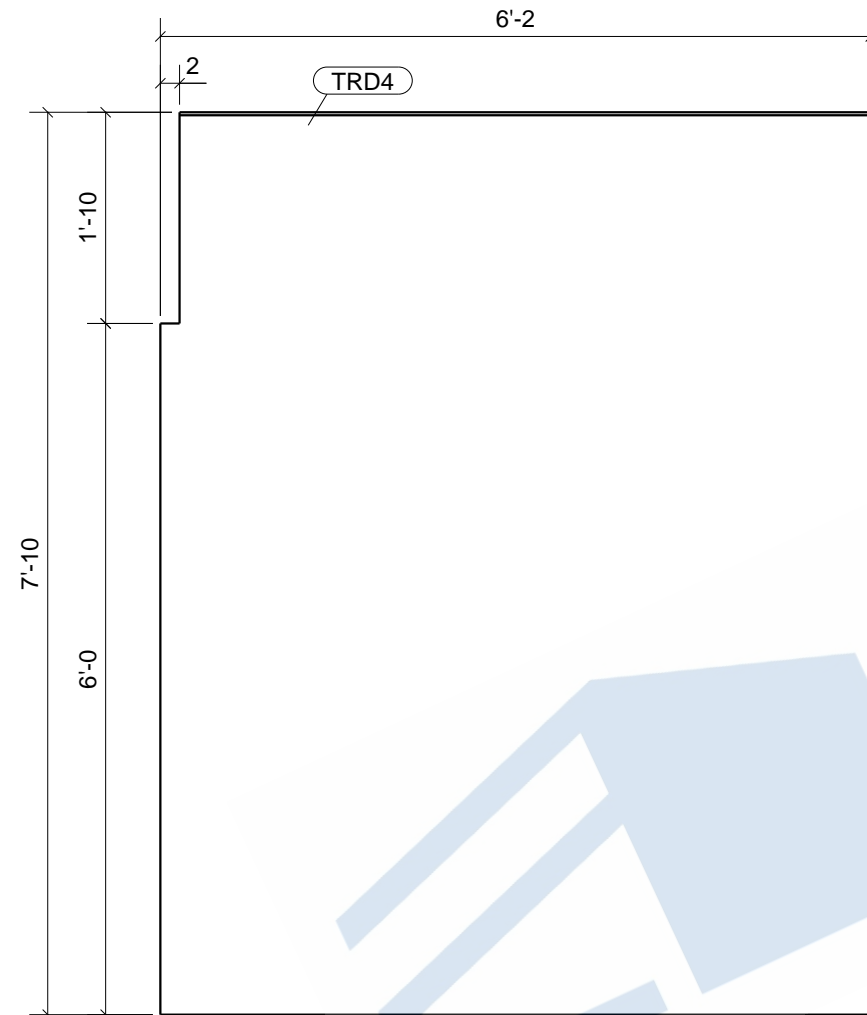

**2 - LANDING PANS - TRD4**

DRAWING STATUS			
SHOP PAINT:	2.5 MILS DFT	13/16" Ø HOLES(U.N.O.)	ALL STEEL TO ASTM A36 U.N.O.
NO PAINT		3/4" BOLTS, ST (U.N.O.)	ALL WELD TO BE E70 LH (U.N.O.)
PROJECT: TRULIANT MONUMENTAL STAIR			DRAWN BY: DSA
DESCRIPTION: LANDING PAN			CHECKED BY: RAD
ARCH:		ENG:	JOB NO:
CUSTOMER:			SHEET NO: TRD4

BILL OF MATERIAL					
MARK	QTY	DESCRIPTION	LENGTH	WEIGHT	REMARKS
TRD3	2	LANDING PANS			SO-2
TRD3	2	PL5/16"X63 3/4"	6'-0"	814	NO PAINT A36
TOTAL WEIGHT THIS DRAWING				814	

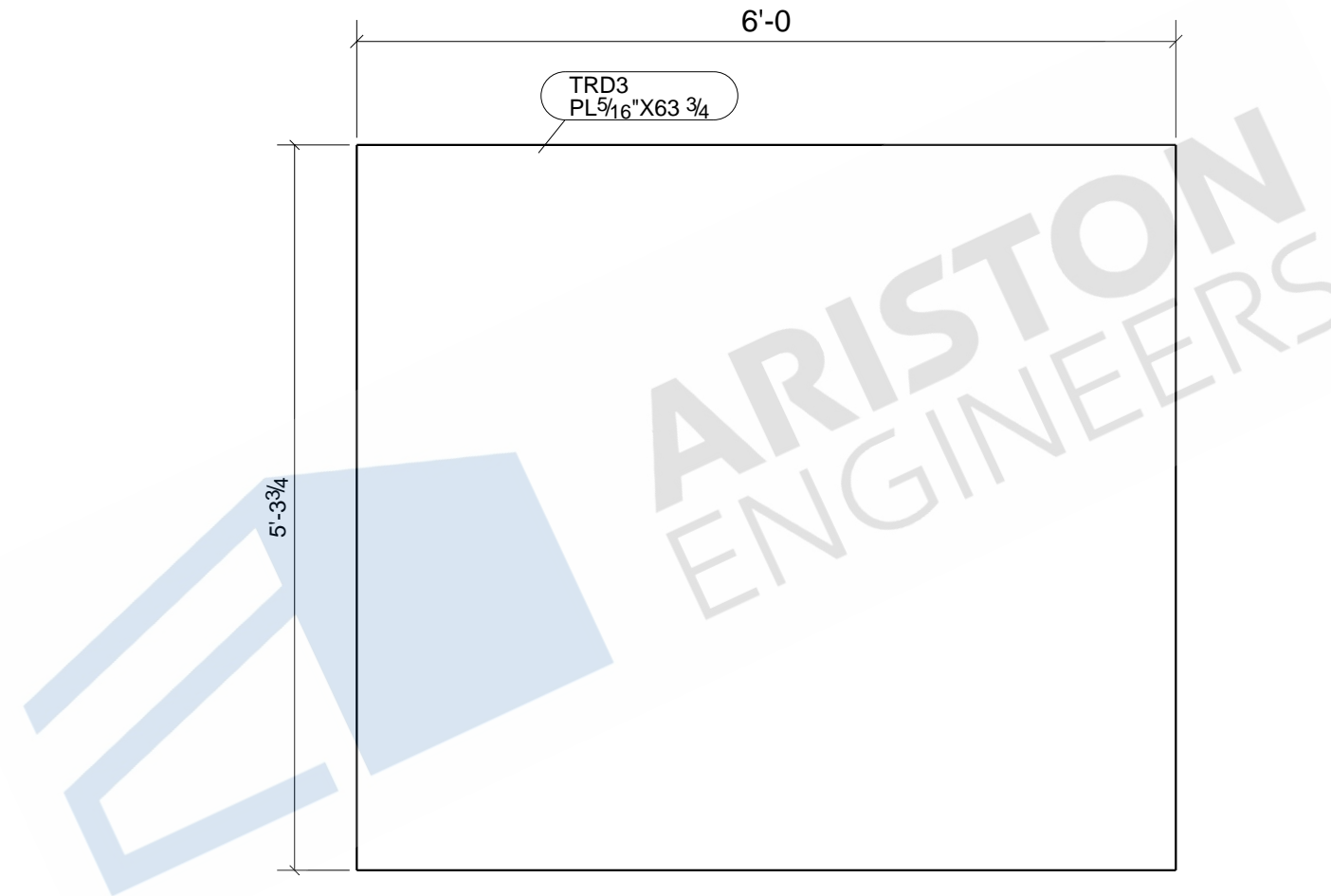

2 - LANDING PANS - TRD3

DRAWING STATUS			
SHOP PAINT:	2.5 MILS DFT	13/16" Ø HOLES(U.N.O.)	ALL STEEL TO ASTM A36 U.N.O.
NO PAINT		3/4" BOLTS, ST (U.N.O.)	ALL WELD TO BE E70 LH (U.N.O.)
PROJECT: TRULIANT MONUMENTAL STAIR			DRAWN BY: DSA
DESCRIPTION: LANDING PAN			CHECKED BY: RAD
ARCH:		ENG:	JOB NO:
CUSTOMER:			SHEET NO: TRD3

BILL OF MATERIAL					
MARK	QTY	DESCRIPTION	LENGTH	WEIGHT	REMARKS
TRD2	2	LANDING PANS			SO-2
TRD2	2	PL5/16"X74"	6'-10 1/16"	1072	NO PAINT A36
TOTAL WEIGHT THIS DRAWING				1072	

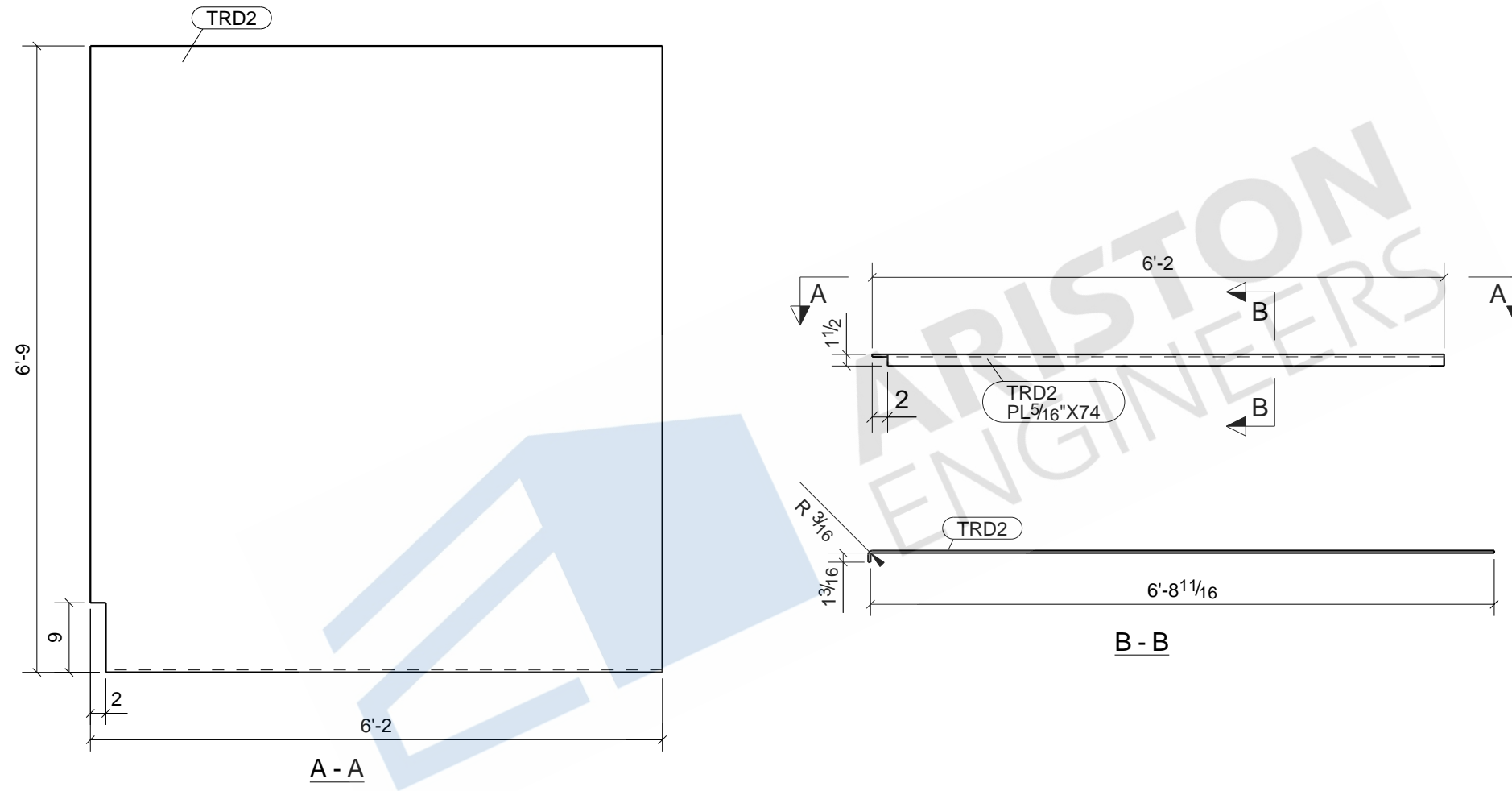

**2 - LANDING PANS - TRD2**

DRAWING STATUS			
SHOP PAINT: NO PAINT	2.5 MILS DFT	13/16" Ø HOLES(U.N.O.)	ALL STEEL TO ASTM A36 U.N.O.
		3/4" BOLTS, ST (U.N.O.)	ALL WELD TO BE E70 LH (U.N.O.)
PROJECT: TRULIANT MONUMENTAL STAIR			DRAWN BY: DSA
DESCRIPTION: LANDING PAN			CHECKED BY: RAD
ARCH:		ENG:	JOB NO:
CUSTOMER:			SHEET NO: TRD2



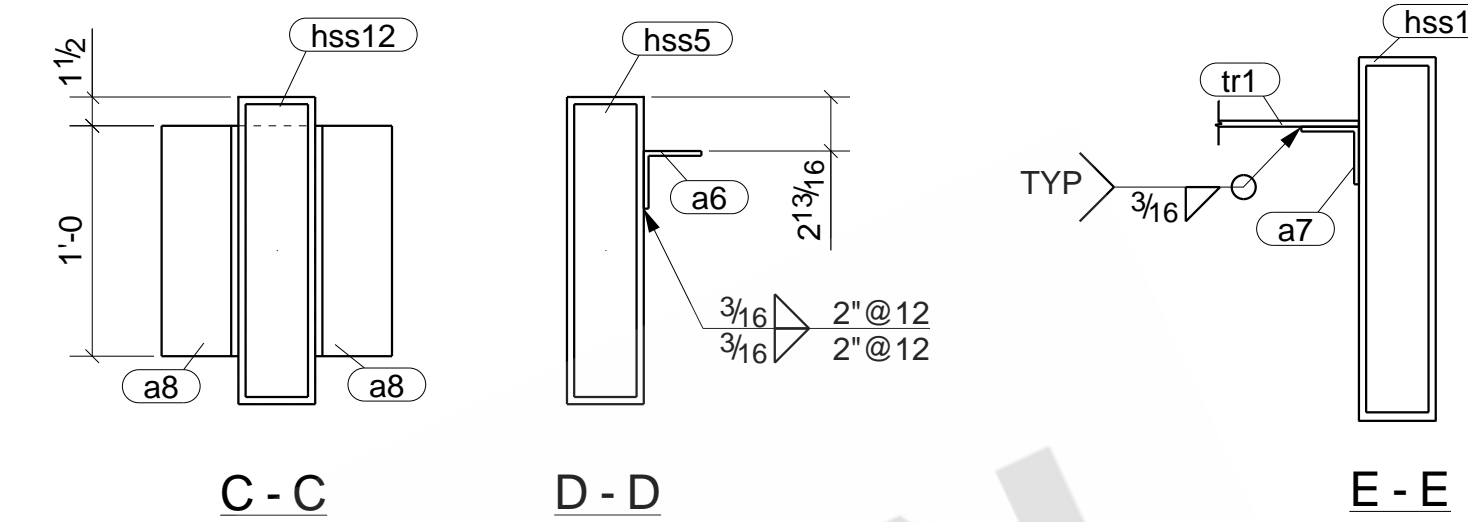
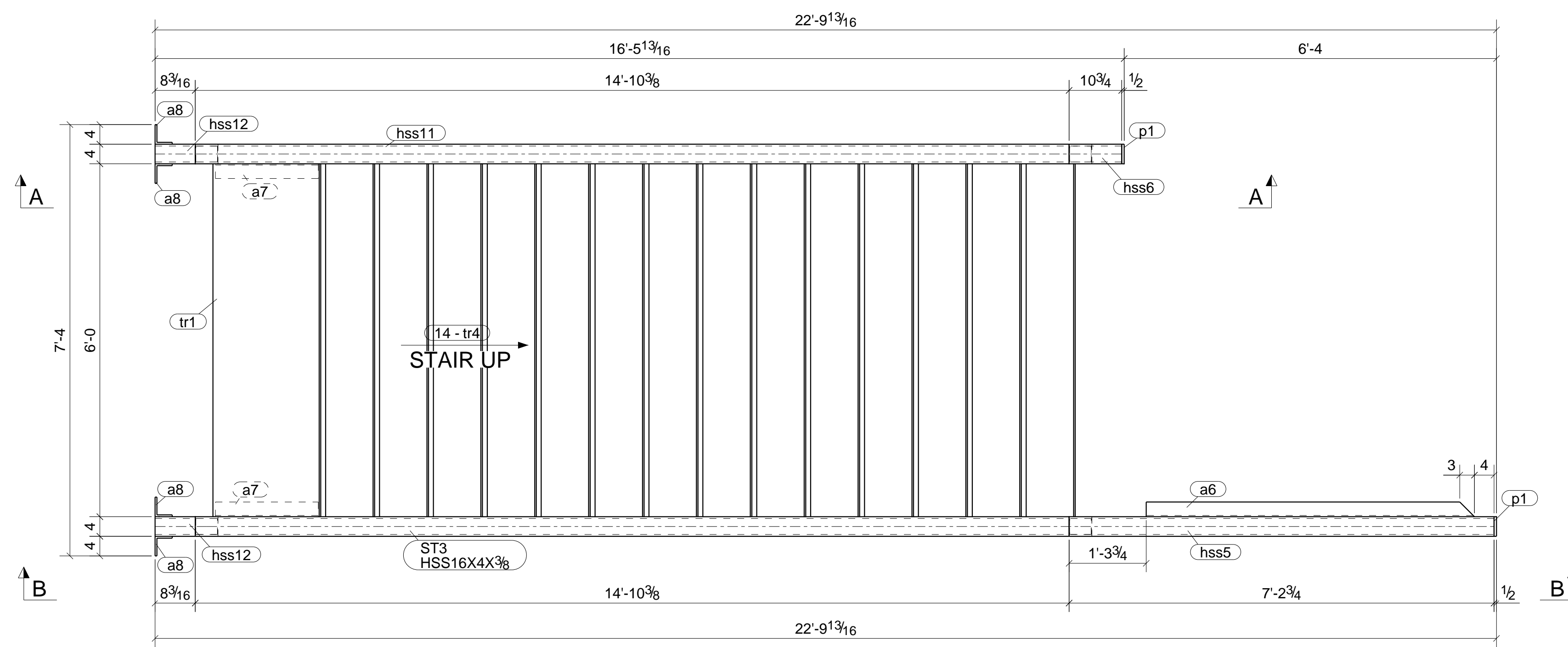

BILL OF MATERIAL						
MARK	QTY	DESCRIPTION	LENGTH	WEIGHT	REMARKS	
ST3	1	STAIR			BEV-2	
ST3	1	HSS16X4X3/8	17'-11 13/16	808	SHOP PRIME	A500-GR. B
a6	1	L3X3X1/4	5'-7"	27		A36
a7	2	L3X3X1/4	1'-9"	17		A36
a8	4	L4X3-1/2X3/8	1'-0"	36		A36
hss5	1	HSS16X4X3/8	7'-2 3/4"	325		A500-GR. B
hss6	1	HSS16X4X3/8	0'-10 3/4"	40		A500-GR. B
hss11	1	HSS16X4X3/8	17'-11 13/16	808		A500-GR. B
hss12	2	HSS16X4X3/8	1'-0 13/16"	96		A500-GR. B
p1	2	PL1/2"X4"	1'-4"	18		A36
tr1	1	PL5/16"X23 5/16"	6'-0"	149		A36
tr4	14	PL5/16"X12 3/8"	6'-0"	1100		A36
TOTAL WEIGHT THIS DRAWING				3424		

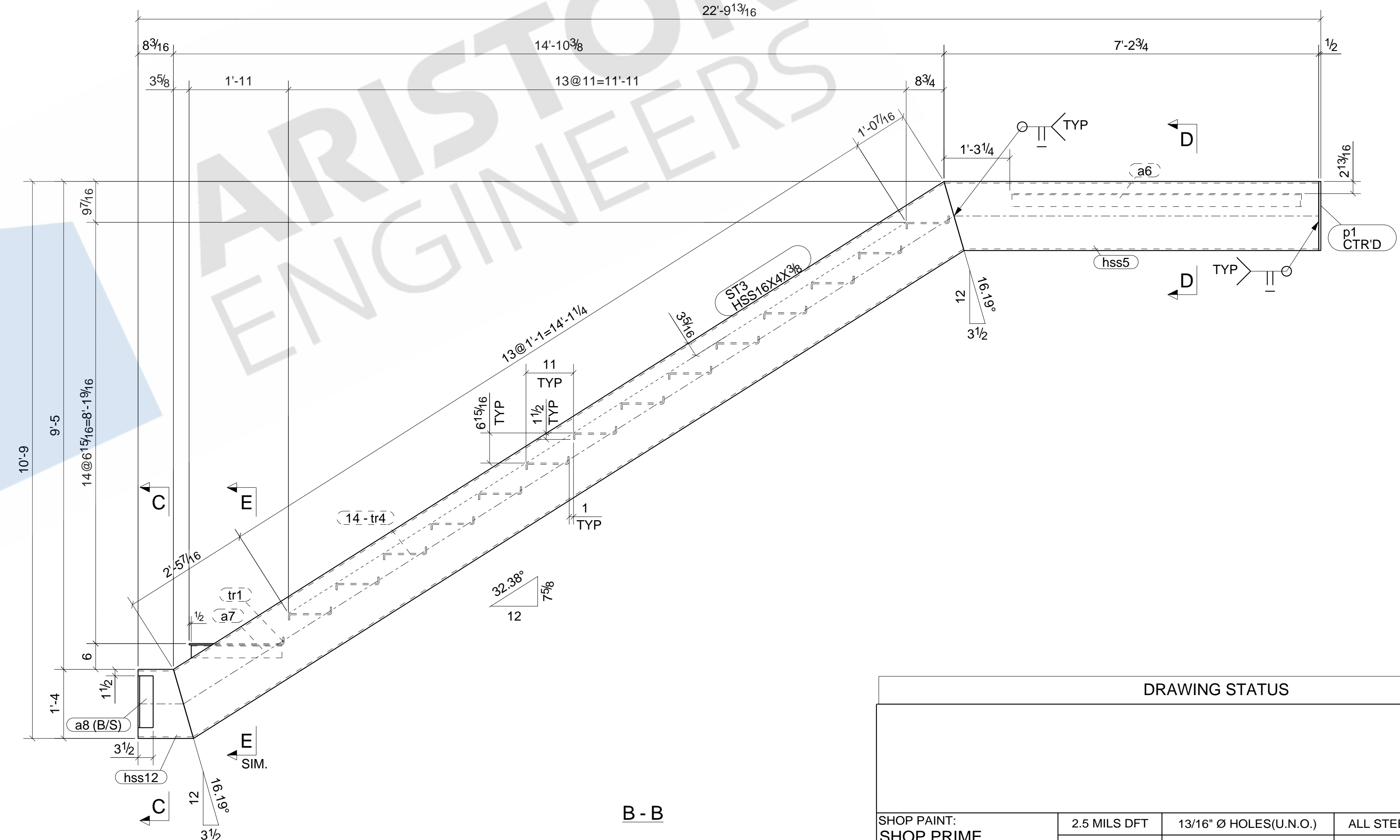
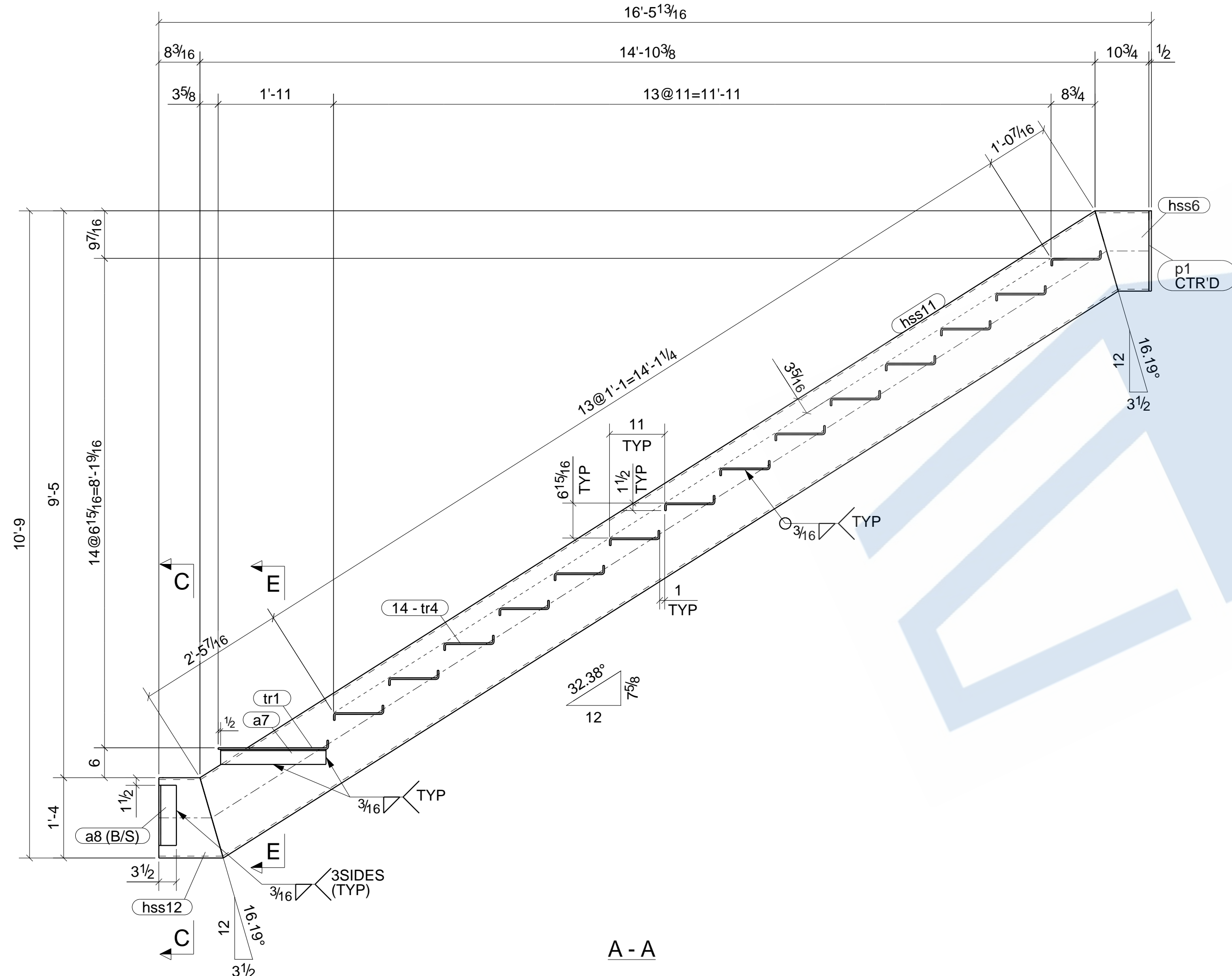

ONE - STAIR - ST3

DRAWING STATUS			
SHOP PAINT:	2.5 MILS DFT	13/16" Ø HOLES (U.N.O.)	ALL STEEL TO ASTM A36 U.N.O.
SHOP PRIME		3/4" BOLTS, ST (U.N.O.)	ALL WELD TO BE E70 LH (U.N.O.)
PROJECT:	TRULIANT MONUMENTAL STAIR		
DESCRIPTION:	STAIR		
ARCH:	ENG:		
CUSTOMER:			
	DRAWN BY:	DSA	
	CHECKED BY:	RAD	
	JOB NO:		
	SHEET NO:	ST3	

### BILL OF MATERIAL

MARK	QTY	DESCRIPTION	LENGTH	WEIGHT	REMARKS
ST2	2	STAIRS			BEV-2
ST2	2	HSS16X4X3/8	16'-5 3/16"	1476	SHOP PRIME A500-GR.B
a2	2	L3X3X1/4	5'-7"	55	A36
a7	4	L3X3X1/4	1'-9"	34	A36
a8	8	L4X3-1/2X3/8	1'-0"	73	A36
hss7	2	HSS16X4X3/8	16'-5 3/16"	1476	A500-GR.B
hss8	4	HSS16X4X3/8	2'-1 7/16"	381	A500-GR.B
hss9	2	HSS16X4X3/8	7'-5 7/8"	673	A500-GR.B
hss10	2	HSS16X4X3/8	1'-1 7/8"	104	A500-GR.B
hss13	4	HSS16X4X3/8	1'-2 11/16"	220	A500-GR.B
p1	4	PL1/2"X4"	1'-4"	36	A36
p3	4	PL1/2"X2 1/2"	0'-4"	5	A36
p4	4	PL1/2"X4"	0'-6 15/16"	16	A36
tr4	30	PL5/16"X12 3/8"	6'-0"	2357	A36
TOTAL WEIGHT THIS DRAWING				6906	

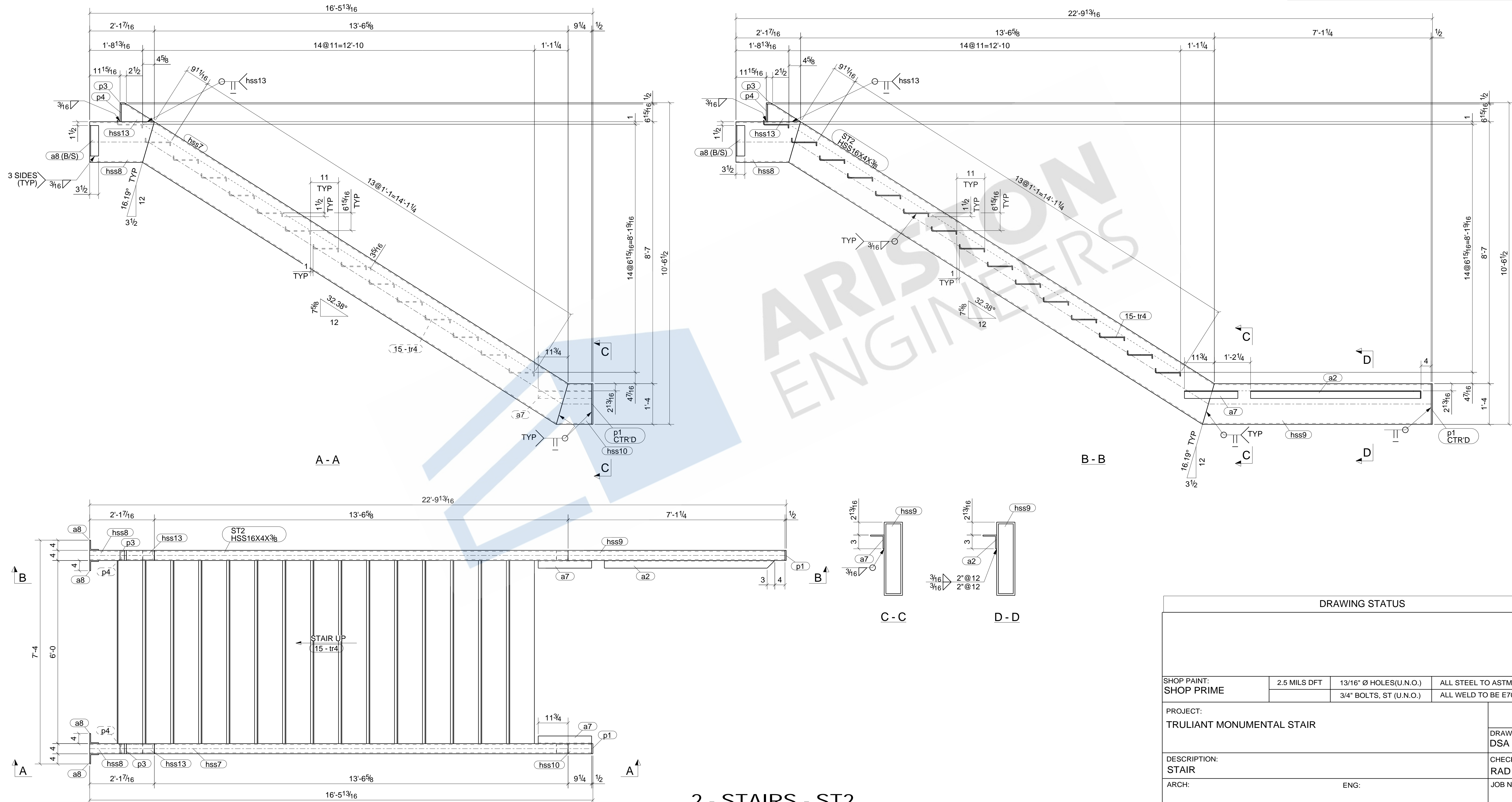

### 2 - STAIRS - ST2

#### DRAWING STATUS

SHOP PAINT:			
SHOP PRIME	2.5 MILS DFT	13/16" Ø HOLES(U.N.O.)	ALL STEEL TO ASTM A36 U.N.O.
		3/4" BOLTS, ST (U.N.O.)	ALL WELD TO BE E70 LH (U.N.O.)
PROJECT:			DRAWN BY:
TRULIANT MONUMENTAL STAIR			
DESCRIPTION:			CHECKED BY:
STAIR			
ARCH:		ENG:	JOB NO:
CUSTOMER:			SHEET NO:
			ST2

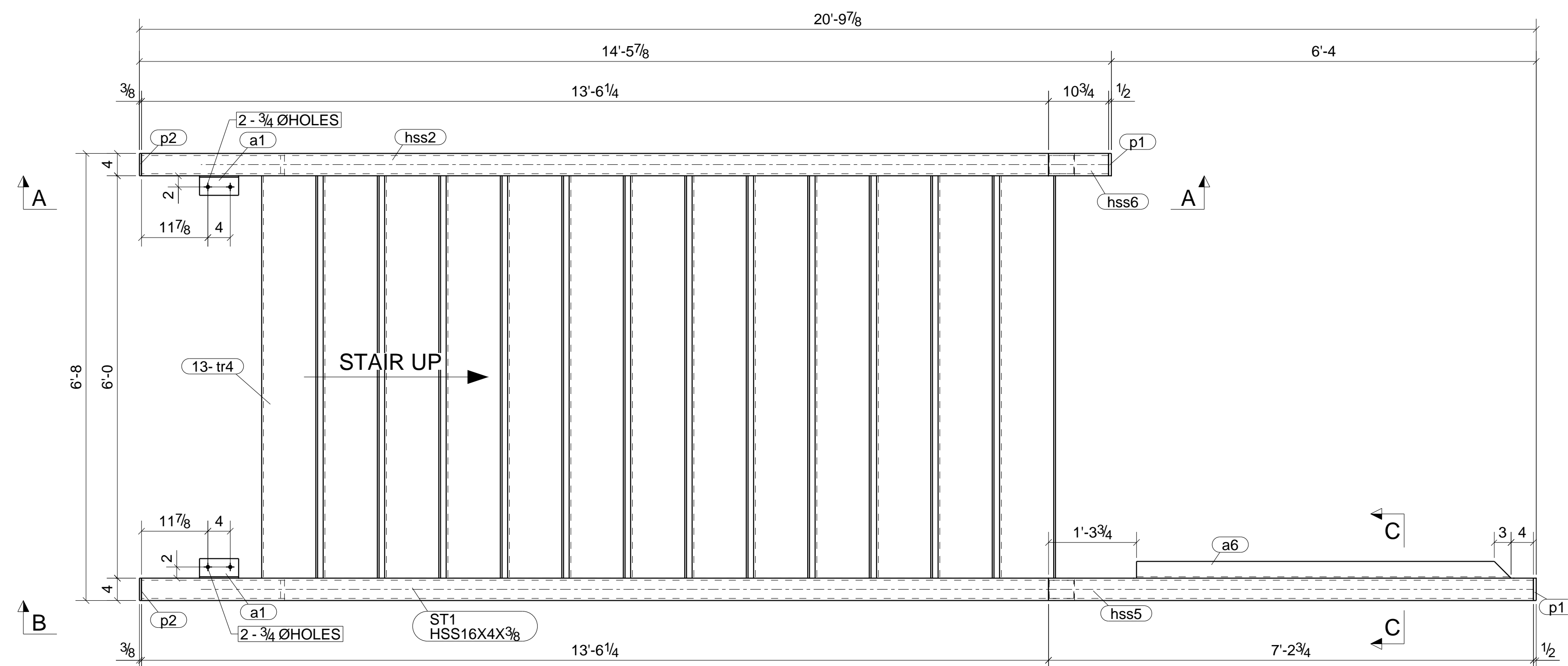

BILL OF MATERIAL					
MARK	QTY	DESCRIPTION	LENGTH	WEIGHT	REMARKS
ST1	1	STAIR			BEV-2
ST1	1	HSS16X4X3/8	16'-1 9/16"	725	SHOP PRIME A500-GR.B
a1	2	L3-12X3X1/4	0'-7"	6	A36
a6	1	L3X3X1/4	5'-7"	27	A36
hss2	1	HSS16X4X3/8	16'-1 9/16"	725	A500-GR.B
hss5	1	HSS16X4X3/8	7'-2 3/4"	325	A500-GR.B
hss6	1	HSS16X4X3/8	0'-10 3/4"	40	A500-GR.B
p1	2	PL1/2"X4"	1'-4"	18	A36
p2	2	PL3/8"X2 3/4"	0'-4"	2	A36
t4	13	PL5/16"X12 3/8"	6'-0"	1021	A36
TOTAL WEIGHT THIS DRAWING				2889	

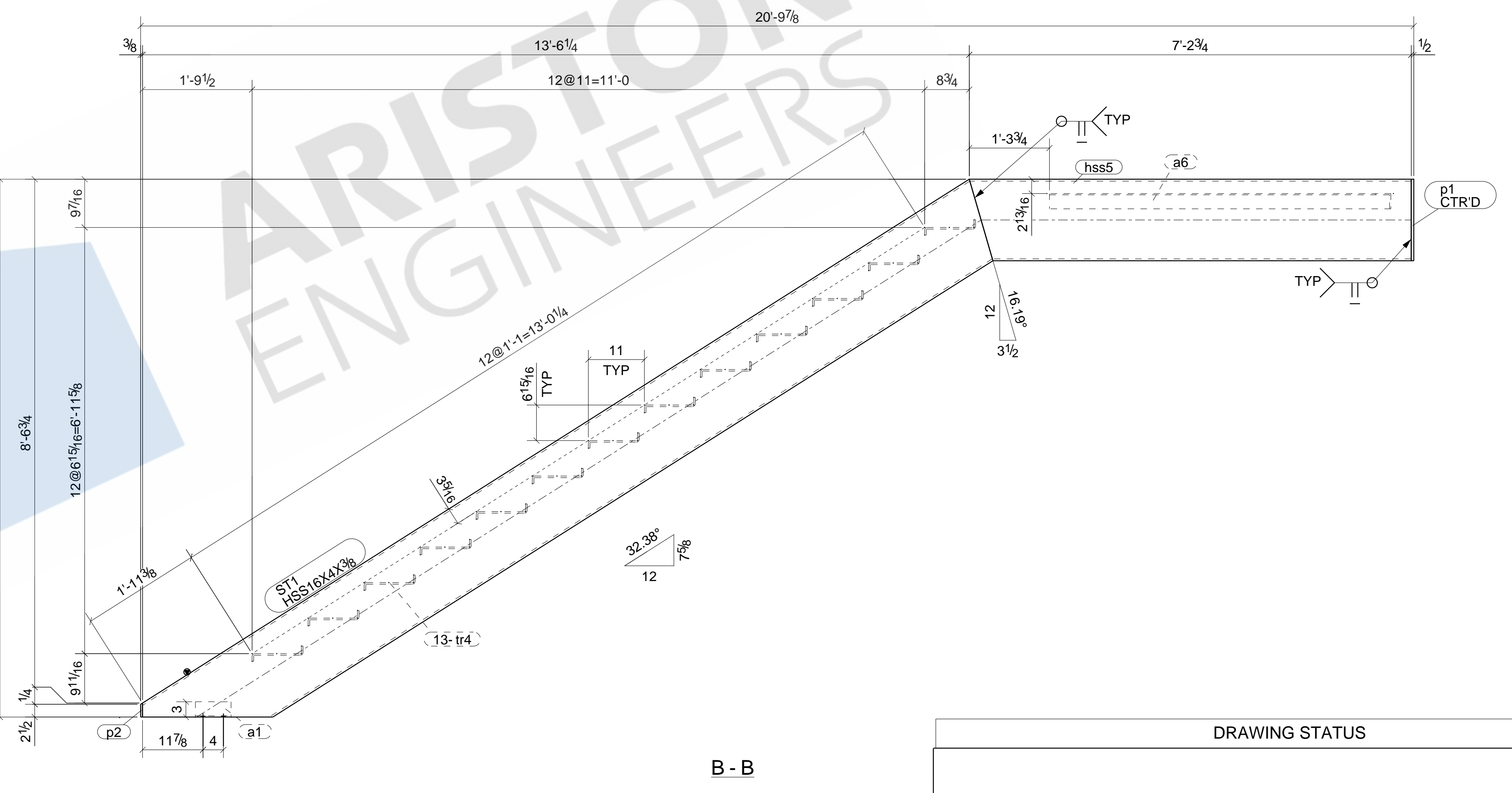
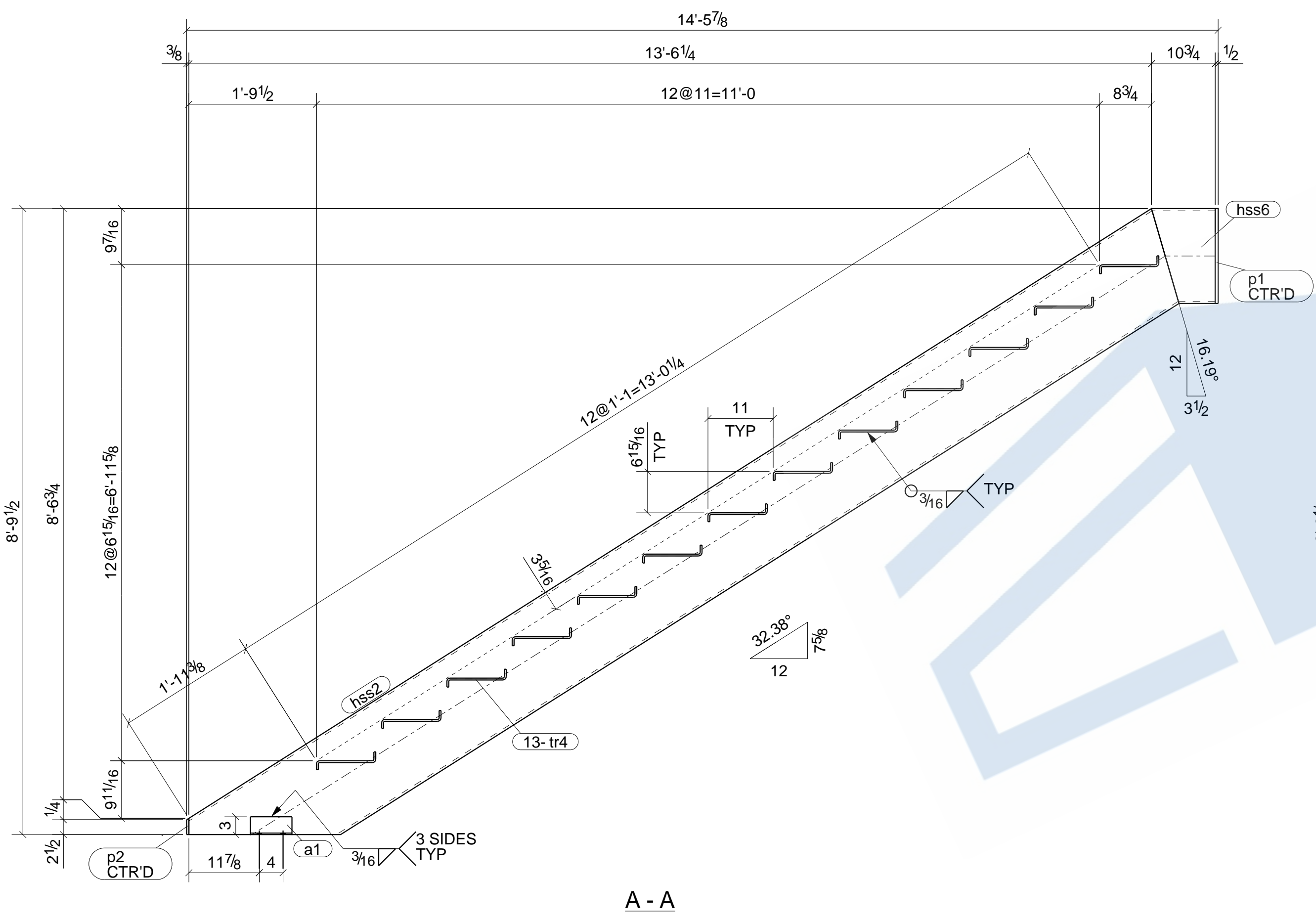
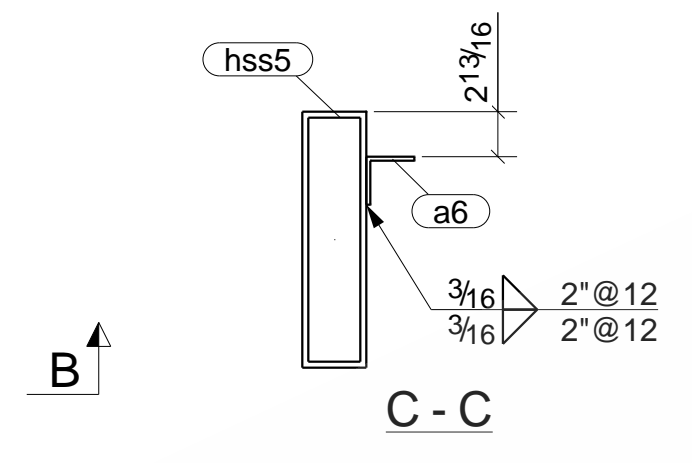

ONE - STAIR - ST1

DRAWING STATUS			
SHOP PAINT:	2.5 MILS DFT	13/16" Ø HOLES (U.N.O.)	ALL STEEL TO ASTM A36 U.N.O.
SHOP PRIME		3/4" BOLTS, ST (U.N.O.)	ALL WELD TO BE E70 LH (U.N.O.)
PROJECT:	TRULIANT MONUMENTAL STAIR		DRAWN BY: DSA
DESCRIPTION:	STAIR		CHECKED BY: RAD
ARCH:	ENG:		JOB NO:
CUSTOMER:			SHEET NO: ST1

BILL OF MATERIAL					
MARK	QTY	DESCRIPTION	LENGTH	WEIGHT	REMARKS
TRD1	1	TREAD PAN			SO-2
TRD1	1	PL 5/16" X 12 3/8"	6'-0"	79	NO PAINT A36
TOTAL WEIGHT THIS DRAWING				79	

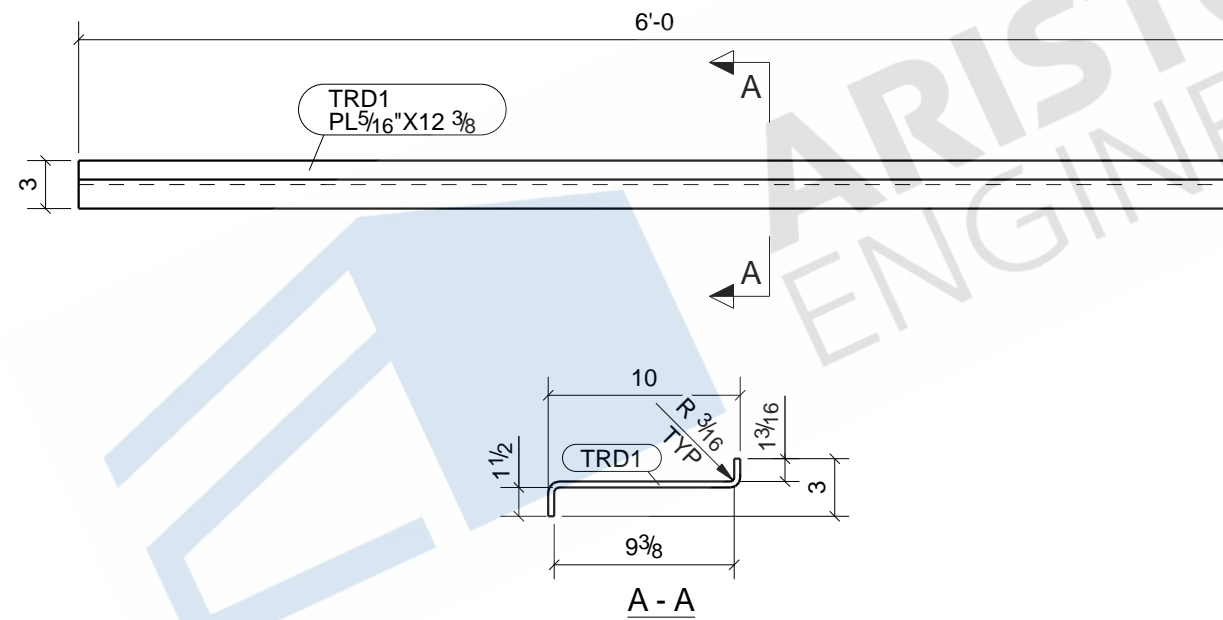

ONE - TREAD PAN - TRD1

DRAWING STATUS			
SHOP PAINT: NO PAINT	2.5 MILS DFT	13/16" Ø HOLES(U.N.O.)	ALL STEEL TO ASTM A36 U.N.O.
		3/4" BOLTS, ST (U.N.O.)	ALL WELD TO BE E70 LH (U.N.O.)
PROJECT: TRULIANT MONUMENTAL STAIR			DRAWN BY: DSA
DESCRIPTION: TREAD PAN			CHECKED BY: RAD
ARCH:		ENG:	JOB NO:
CUSTOMER:			SHEET NO: TRD1